

PROJECT NAME

CERULEAN

BASED ON

Marshall Bluesbreaker

EFFECT TYPE

Amp-Like Overdrive

BUILD DIFFICULTY

■■■■■ Easy

DOCUMENT VERSION

1.0.1 (2018-08-14)

aion
DIY GUITAR EFFECTS

PROJECT SUMMARY

A classic overdrive effect that was designed to mimic the Marshall Bluesbreaker amplifier from the 1960s, the Bluesbreaker is also the source circuit for a number of high-dollar “boutique” guitar pedals.

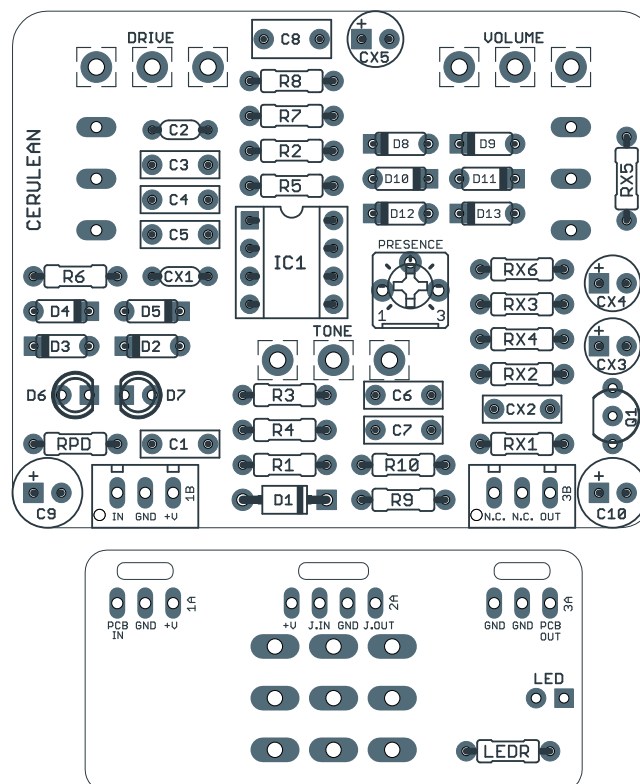

Actual size is 2.3" x 1.86" (main board) and 2.3" x 0.86" (bypass board).

TABLE OF CONTENTS

| | | | |
|-----|----------------------|----|--------------------|
| 1 | Project Overview | 7 | Drill Template |
| 2 | Introduction & Usage | 8 | Enclosure Layout |
| 3-4 | Parts List | 9 | Wiring Diagram |
| 5 | Build Notes | 10 | Licensing |
| 6 | Schematic | 10 | Document Revisions |

INTRODUCTION

The Cerulean Amp Overdrive is an updated version of the Marshall Bluesbreaker pedal. The Bluesbreaker is the source circuit for a number of expensive boutique pedals including the Analogman King of Tone (which is two Bluesbreakers in the same box with a few modifications).

The Cerulean project has integrated two of the modifications from the King of Tone: the Presence control (an internal trimmer) and the ability to control both the soft clipping (stock) and hard clipping diodes. The clipping switches have been expanded further to allow two different diode combinations for both hard and soft clipping, whereas the King of Tone only has “on” and “off” settings for each.

Another notable clone of the Bluesbreaker is the JHS Morning Glory, which added a JFET gain stage at the end for increased output volume. The Cerulean project provides the option of using the output stage of the Morning Glory. See the build notes for more information.

During the development of this updated version of the Cerulean, it was determined that the “Bright” switch of the Morning Glory was not very useful, especially when there was already a Tone control and an internal Presence control, both of which affect the high end. The original Bluesbreaker doesn’t filter out any of the treble in the clipping stage, so in fact the Morning Glory is really no brighter than a stock Bluesbreaker, and instead only adds the option to get darker. Accordingly, this option has been removed in favor of simplifying the decisionmaking process when deciding how to build it.

However, if you do want to make an exact clone of the Morning Glory including the Bright switch, you can use the earlier version of the Cerulean which will continue to be available for the foreseeable future.

USAGE

The Bluesbreaker has the same control layout as most overdrive or distortion effects:

- **Tone** controls the treble response of the effect.
- **Drive** controls the amount of gain in the op-amp feedback diode clipping stage.
- **Volume** controls the overall output.
- An internal **Presence** control allows you to tweak the overall response of the tone knob.
- **Soft Clipping** lets you choose between stock clipping diodes, LEDs, or no soft clipping.
- **Hard Clipping** lets you select high-threshold hard clipping, low-threshold hard clipping, or none.

PARTS LIST

This parts list is also available in a spreadsheet format which can be imported directly into Mouser for easy parts ordering. Mouser doesn't carry all the parts—notably potentiometers—so the second tab lists all the non-Mouser parts as well as sources for each.

[View parts list spreadsheet](#) →

| PART | VALUE | TYPE | NOTES |
|------|-------|-------------------------------|---|
| R1 | 1M | Metal film resistor, 1/4W | |
| R2 | 3k3 | Metal film resistor, 1/4W | |
| R3 | 4k7 | Metal film resistor, 1/4W | |
| R4 | 10k | Metal film resistor, 1/4W | |
| R5 | 220k | Metal film resistor, 1/4W | |
| R6 | 6k8 | Metal film resistor, 1/4W | |
| R7 | 1k | Metal film resistor, 1/4W | |
| R8 | 6k8 | Metal film resistor, 1/4W | |
| R9 | 47k | Metal film resistor, 1/4W | |
| R10 | 47k | Metal film resistor, 1/4W | |
| RX1 | 100k | Metal film resistor, 1/4W | Part of the optional Morning Glory gain stage. (see build notes) |
| RX2 | 68k | Metal film resistor, 1/4W | Part of the optional Morning Glory gain stage. (see build notes) |
| RX3 | 1M | Metal film resistor, 1/4W | Part of the optional Morning Glory gain stage. (see build notes) |
| RX4 | 22k | Metal film resistor, 1/4W | Part of the optional Morning Glory gain stage. (see build notes) |
| RX5 | 12k | Metal film resistor, 1/4W | Part of the optional Morning Glory gain stage. (see build notes) |
| RX6 | 12k | Metal film resistor, 1/4W | Part of the optional Morning Glory gain stage. (see build notes) |
| RPD | 2M2 | Metal film resistor, 1/4W | Input pulldown resistor. Can be as low as 1M. |
| LEDR | 4k7 | Metal film resistor, 1/4W | LED current-limiting resistor. Adjust value to change LED brightness. |
| C1 | 10n | Film capacitor, 7.2 x 2.5mm | |
| C2 | 47pF | MLCC capacitor, NP0/COG | |
| C3 | 10n | Film capacitor, 7.2 x 2.5mm | |
| C4 | 10n | Film capacitor, 7.2 x 2.5mm | |
| C5 | 100n | Film capacitor, 7.2 x 2.5mm | |
| C6 | 10n | Film capacitor, 7.2 x 2.5mm | |
| C7 | 10n | Film capacitor, 7.2 x 2.5mm | |
| C8 | 100n | Film capacitor, 7.2 x 2.5mm | Omit if using Morning Glory gain stage. (see build notes) |
| C9 | 100uF | Electrolytic capacitor, 6.3mm | Power supply filter capacitor. |
| C10 | 100uF | Electrolytic capacitor, 6.3mm | Voltage reference filter capacitor. |
| CX1 | 100pF | MLCC capacitor, NP0/COG | Optional high-frequency feedback capacitor. |
| CX2 | 100n | Film capacitor, 7.2 x 2.5mm | Part of the optional Morning Glory gain stage. (see build notes) |

PARTS LIST, CONT.

| PART | VALUE | TYPE | NOTES |
|-------|--------------|--------------------------------|---|
| CX3 | 10uF | Electrolytic capacitor, 5mm | Part of the optional Morning Glory gain stage. (see build notes) |
| CX4 | 2.2uF | Electrolytic capacitor, 4mm | Part of the optional Morning Glory gain stage. (see build notes) |
| CX5 | OMIT | Electrolytic capacitor, 4mm | 1uF is used in the King of Tone variant. |
| D1 | 1N5817 | Schottky diode, DO-41 | |
| D2 | 1N914 | Fast-switching diode, DO-35 | |
| D3 | 1N914 | Fast-switching diode, DO-35 | |
| D4 | 1N914 | Fast-switching diode, DO-35 | |
| D5 | 1N914 | Fast-switching diode, DO-35 | |
| D6 | LED | LED, 3mm, red diffused | |
| D7 | LED | LED, 3mm, red diffused | |
| D8 | 1N914 | Fast-switching diode, DO-35 | |
| D9 | 1N914 | Fast-switching diode, DO-35 | |
| D10 | 1N914 | Fast-switching diode, DO-35 | |
| D11 | 1N914 | Fast-switching diode, DO-35 | |
| D12 | 1N914 | Fast-switching diode, DO-35 | |
| D13 | 1N914 | Fast-switching diode, DO-35 | |
| Q1 | 2N5457 | JFET, N-channel, TO-92 | Part of the optional Morning Glory gain stage. (see build notes) |
| IC1 | TL072 | Operational amplifier, DIP8 | |
| PRES | 50k trimmer | Trimmer, 10%, 1/4" | |
| HARD | SPDT | Toggle switch, SPDT, on-off-on | Hard clipping (low, high or none) |
| SOFT | SPDT | Toggle switch, SPDT, on-off-on | Soft clipping (low, high or none) |
| DRIVE | 100kB | 16mm right-angle PCB mount pot | Linear taper. |
| TONE | 25kB | 16mm right-angle PCB mount pot | Linear taper. |
| VOL | 100kA | 16mm right-angle PCB mount pot | Audio (log) taper. |
| IN | 1/4" stereo | 1/4" phone jack, closed frame | Switchcraft 112BX or equivalent. |
| OUT | 1/4" mono | 1/4" phone jack, closed frame | Switchcraft 111X or equivalent. |
| DC | 2.1mm | DC jack, 2.1mm panel mount | Mouser 163-4302-E or equivalent. |
| BATT | Battery snap | 9V battery snap | Optional. Use the soft plastic type—the hard-shell type will not fit. |
| FSW | 3PDT | Stomp switch, 3PDT | |
| ENC | 125B | Enclosure, die-cast aluminum | Can also use a Hammond 1590N1. |

BUILD NOTES

Morning Glory Gain Stage

The JHS Morning Glory adds another gain stage to the end of the circuit for more available output volume. You can choose to build the pedal with this gain stage or without.

To build with the gain stage, **omit C8** and include **RX1-6, CX2-4** and **Q1**.

To build without the gain stage, **include C8** and omit **RX1-6, CX2-4** and **Q1**.

King of Tone

The Analogman King of Tone is two Bluesbreakers in one box. All of the modifications from the King of Tone are available as part of this project (soft clipping, hard clipping, and Presence control).

If you use a 1790NS enclosure you could fit two of these side by side. Information on this will be provided for this at a later date, but as of right now it is outside the scope of the documentation.

High Gain Mod

To increase the available gain, you can change the Gain pot to **250kB** (from 100kB). The full stock range is still available on the first half of the rotation, but you now have increased range on the second half.

SCHEMATIC

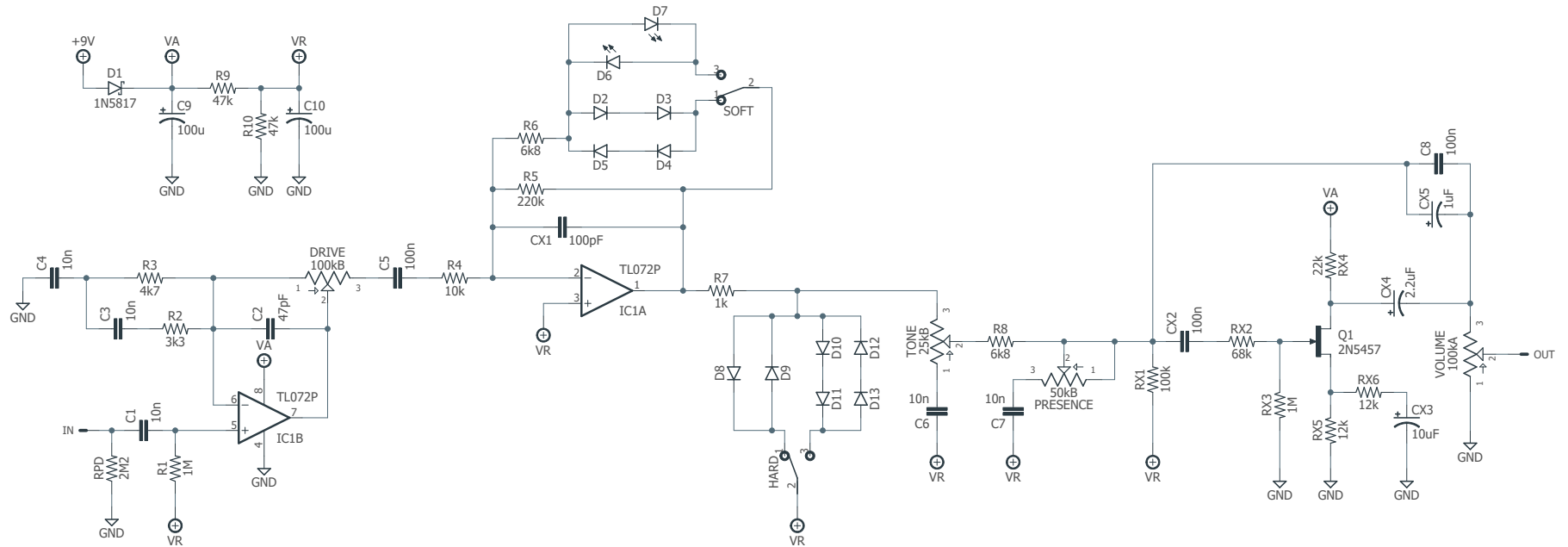

DRILL TEMPLATE

Cut out this drill template, fold the edges and tape it to the enclosure. Before drilling, it's recommended to first use a center punch for each of the holes to help guide the drill bit.

Ensure that this template is printed at 100% or "Actual Size". You can double-check this by measuring the scale on the printed page.

Top jack layout assumes the use of closed-frame jacks like the [Switchcraft 111X](#). If you'd rather use open-frame jacks, please refer to the Open-Frame Jack Drill Template for the top side.

LED hole drill size assumes the use of a [5mm LED bezel](#), available from several parts suppliers. Adjust size accordingly if using something different, such as a 3mm bezel, a plastic bezel, or just a plain LED.

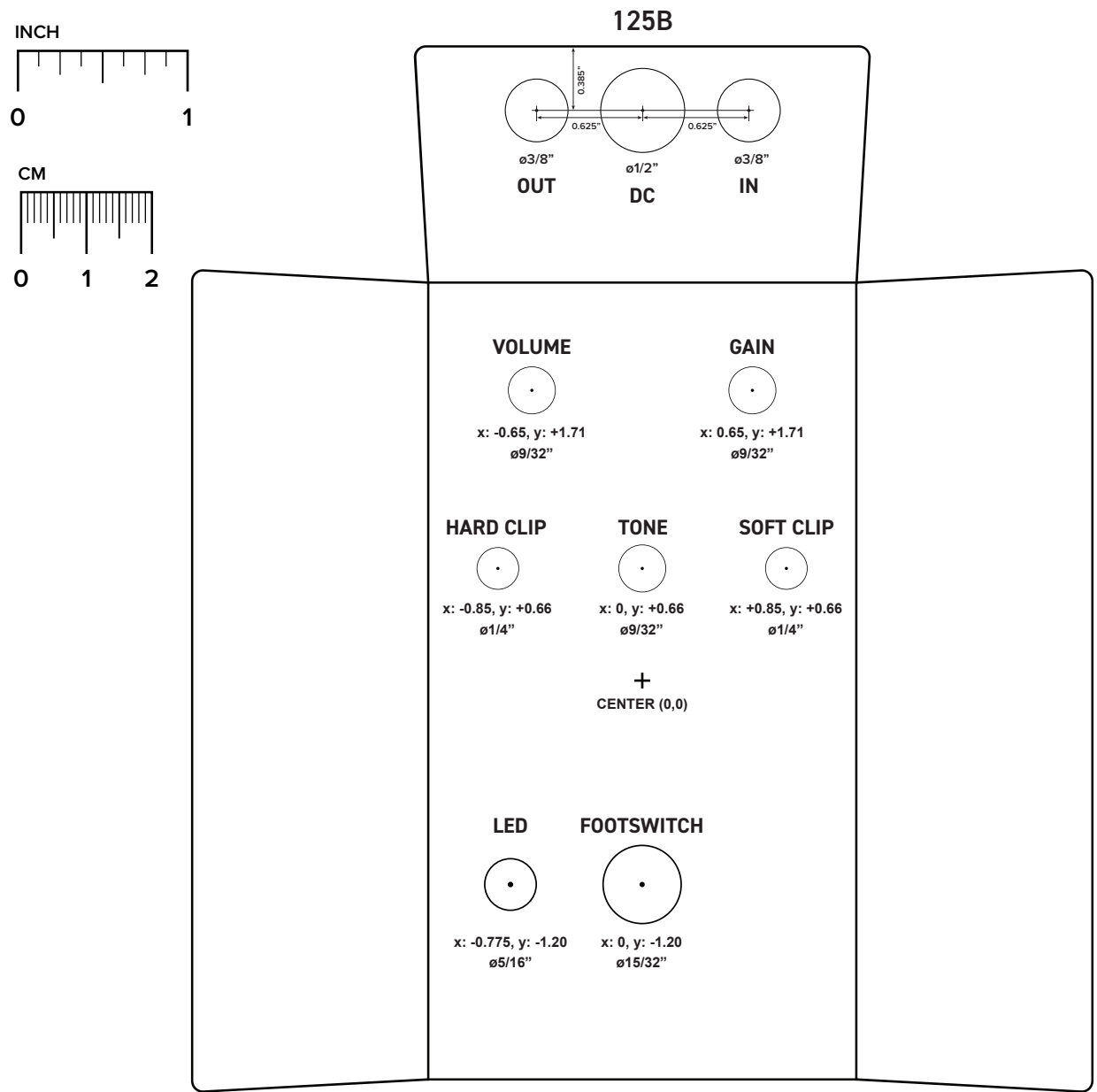

ENCLOSURE LAYOUT

Enclosure is shown without jacks. See next page for jack layout and wiring.

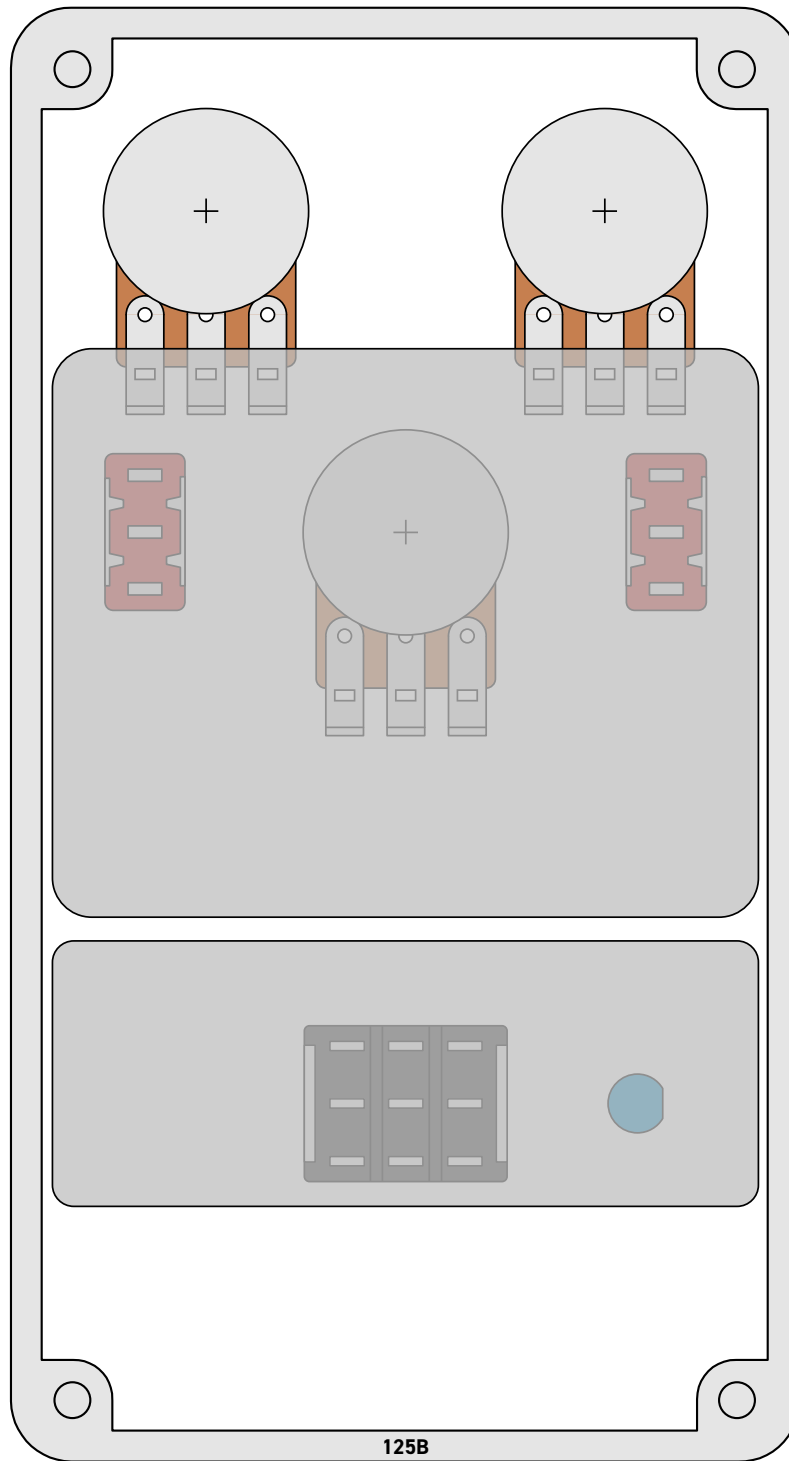

WIRING DIAGRAM

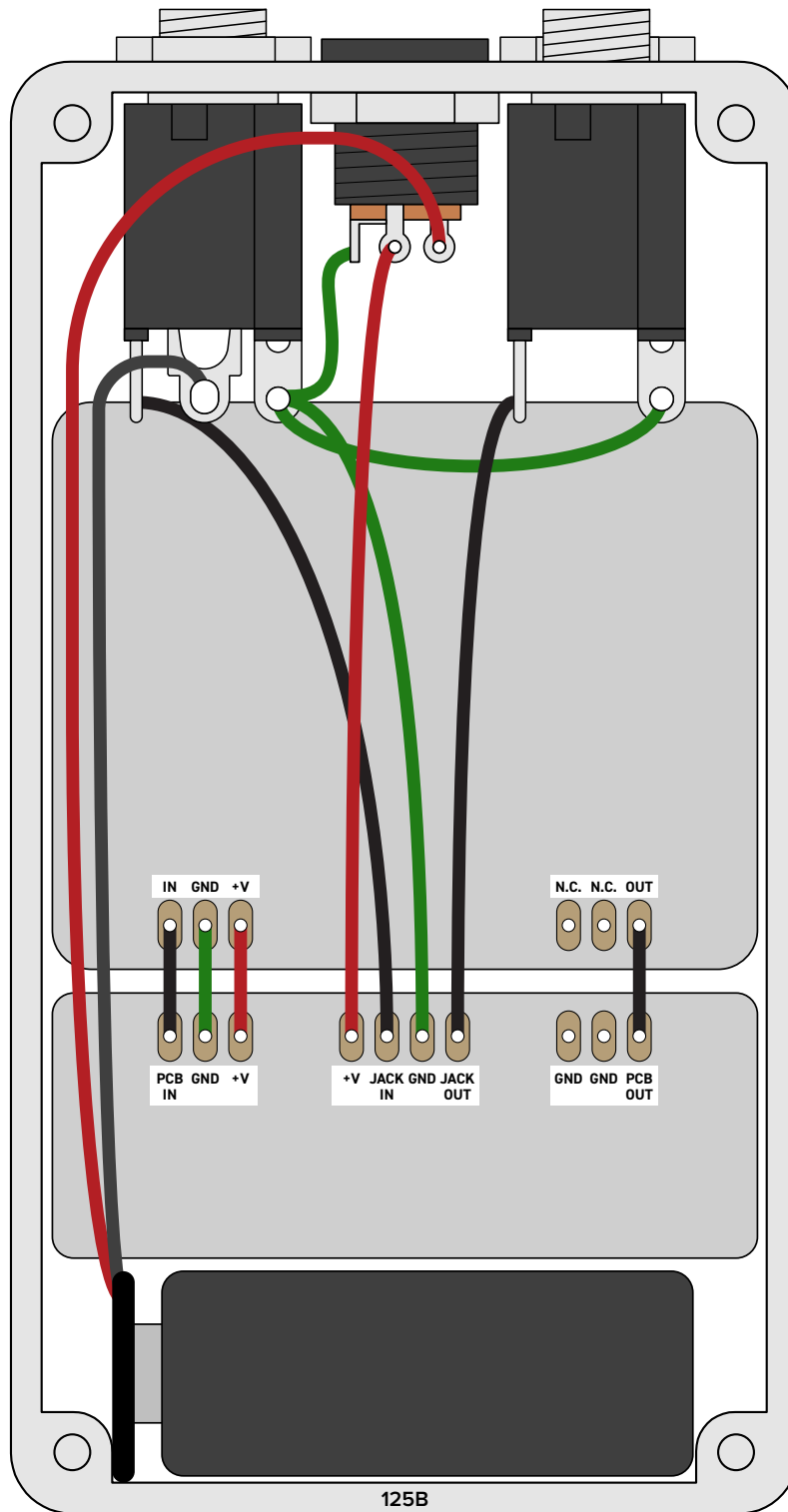

*Shown with optional 9V battery. If battery is omitted, both jacks can be mono rather than one being stereo.
Leave the far-right lug of the DC jack unconnected.*

LICENSE & USAGE

No direct support is offered for these projects beyond the provided documentation. It's assumed that you have at least some experience building pedals before starting one of these. Replacements and refunds cannot be offered unless it can be shown that the circuit or documentation are in error.

All of these circuits have been tested in good faith in their base configurations. However, not all the modifications or variations have necessarily been tested. These are offered only as suggestions based on the experience and opinions of others.

Projects may be used for commercial endeavors in any quantity unless specifically noted. No attribution is necessary, though a link back is always greatly appreciated. The only usage restrictions are that **(1) you cannot resell the PCB as part of a kit without prior arrangement, and (2) you cannot "goop" the circuit, scratch off the screenprint, or otherwise obfuscate the circuit to disguise its source.** (In other words: you don't have to go out of your way to advertise the fact that you use these PCBs, but please don't go out of your way to hide it. The guitar effects industry needs more transparency, not less!)

DOCUMENT REVISIONS

1.0.1 (2018-08-14)

Corrected parts list to specify LEDs for D6 and D7. Minor formatting adjustments.

1.0.0 (2018-07-04)

Initial release.