

PROJECT NAME

HELIOS

BASED ON

Pro Co RAT Distortion

EFFECT TYPE

Distortion

BUILD DIFFICULTY

■■■■■ Easy

DOCUMENT VERSION

1.0.0 (2018-08-22)



PROJECT SUMMARY

A distortion pedal with a very distinctive and tight mid-to-high-gain character that made it a staple in the rigs of 1980s hard rock bands.

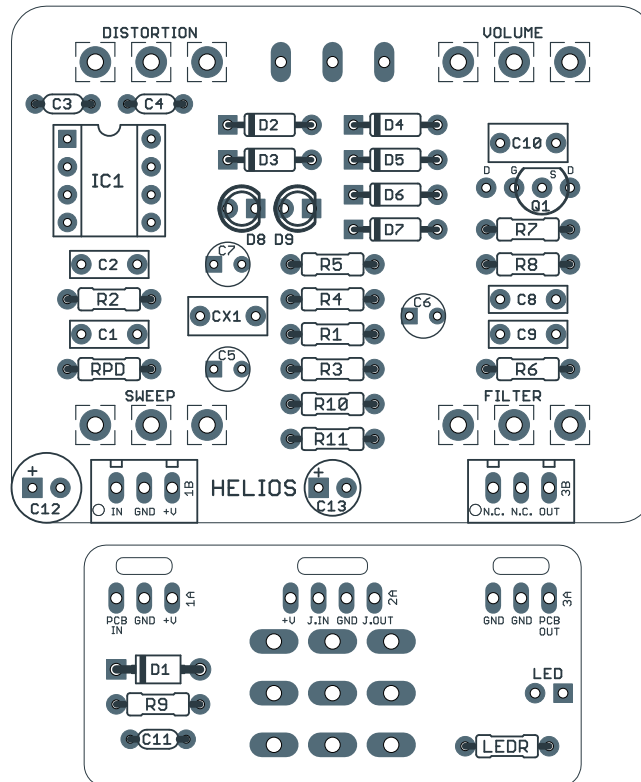

Actual size is 2.3" x 1.86" (main board) and 2.3" x 0.86" (bypass board).

TABLE OF CONTENTS

1	Project Overview	7	Drill Template
2	Introduction & Usage	8	Enclosure Layout
3-4	Parts List	9	Wiring Diagram
5	Build Notes	10	Licensing
6	Schematic	10	Document Revisions

INTRODUCTION

The Helios Classic Distortion is a recreation of the Pro Co RAT Distortion. First released in 1978, it went through several iterations over the next few decades and was released under other names like the RAT2 and Turbo RAT. The core circuit remained essentially the same throughout its lifespan.

The RAT can be considered an evolution of the MXR Distortion+. It has the same basic op-amp gain stage followed by diode-to-ground clipping. However, it also significantly alters the EQ in the op-amp stage as well as adding a tone control and output buffer.

The Helios adds two modifications: a clipping switch to select between different sets of diodes, and a Sweep control that changes the EQ and gain structure.

The new 125B version of the Helios has been overhauled, reducing some flexibility in favor of an easier and more straightforward build. The previous version of the Helios will remain available.

USAGE

The Helios has the same control layout as most overdrive or distortion effects:

- **Filter** is a tone control. It works backwards from the traditional tone control operation, cutting treble as you turn it clockwise.
- **Distortion** controls the amount of gain in the op-amp gain stage that is then clipped in a later stage.
- **Volume** controls the overall output of the effect.

In addition, there are two modifications included for added flexibility:

- **Sweep** (knob) changes the cutoff frequency of one of the high-pass filters in the op-amp stage, allowing more low end to pass through and thickening the tone.
- **Clipping** (toggle switch) selects between different sets of clipping diodes which changes the character of the drive tone.

PARTS LIST

This parts list is also available in a spreadsheet format which can be imported directly into Mouser for easy parts ordering. Mouser doesn't carry all the parts—notably potentiometers—so the second tab lists all the non-Mouser parts as well as sources for each.

[View parts list spreadsheet](#) →

PART	VALUE	TYPE	NOTES
R1	1M	Metal film resistor, 1/4W	
R2	1k	Metal film resistor, 1/4W	
R3	47R	Metal film resistor, 1/4W	
R4	560R	Metal film resistor, 1/4W	
R5	1k	Metal film resistor, 1/4W	
R6	1k5	Metal film resistor, 1/4W	
R7	1M	Metal film resistor, 1/4W	
R8	10k	Metal film resistor, 1/4W	
R9	47R	Metal film resistor, 1/4W	
R10	100k	Metal film resistor, 1/4W	
R11	100k	Metal film resistor, 1/4W	
RPD	2M2	Metal film resistor, 1/4W	Input pulldown resistor. Can be as low as 1M.
LEDR	4k7	Metal film resistor, 1/4W	LED current-limiting resistor. Adjust value to change LED brightness.
C1	22n	Film capacitor, 7.2 x 2.5mm	
C2	1n	Film capacitor, 7.2 x 2.5mm	
C3	33pF	MLCC capacitor, NP0/C0G	
C4	100pF	MLCC capacitor, NP0/C0G	
C5	2.2uF	Electrolytic capacitor, 4mm	
C6	4.7uF	Electrolytic capacitor, 4mm	
C7	4.7uF	Electrolytic capacitor, 4mm	Can instead use CX1 for a 1uF film cap. No audible EQ difference between 4.7uF and 1uF and film caps have better sound quality.
C8	3n3	Film capacitor, 7.2 x 2.5mm	
C9	22n	Film capacitor, 7.2 x 2.5mm	
C10	1uF	Film capacitor, 7.2 x 3.5mm	
C11	100n	MLCC capacitor, X7R	Power supply filter capacitor.
C12	100uF	Electrolytic capacitor, 6.3mm	Power supply filter capacitor.
C13	47uF	Electrolytic capacitor, 5mm	Reference voltage filter capacitor.
CX1	1uF	Film capacitor, 7.2 x 3.5mm	Alternative for C7. No audible EQ difference between 4.7uF and 1uF and film caps have better sound quality.

PARTS LIST, CONT.

PART	VALUE	TYPE	NOTES
D1	1N5817	Schottky diode, DO-41	
D2	1N914	Fast-switching diode, DO-35	
D3	1N914	Fast-switching diode, DO-35	
D4	1N914	Fast-switching diode, DO-35	
D5	1N914	Fast-switching diode, DO-35	
D6	1N914	Fast-switching diode, DO-35	
D7	1N914	Fast-switching diode, DO-35	
D8	3mm	LED, 3mm, red diffused	
D9	3mm	LED, 3mm, red diffused	
Q1	2N5457	JFET, N-channel, TO-92	
IC1	OP07	Operational amplifier, DIP8	Original IC is LM308N, but these are very difficult to find. OP07 is said to sound identical and has been used in newer RATs after the 308 became obsolete.
IC1-S	DIP-8 socket	IC socket, DIP-8	
TONE	100kA	16mm right-angle PCB mount pot	
DIST	100kA	16mm right-angle PCB mount pot	
VOL	100kA	16mm right-angle PCB mount pot	
SWEEP	1kB	16mm right-angle PCB mount pot	Modification. Turn it all the way down for the stock RAT circuit.
CLIP	SPDT cntr off	Toggle switch, SPDT on-off-on	
LED	5mm	LED, 5mm, red diffused	
IN	1/4" stereo	1/4" phone jack, closed frame	Switchcraft 112BX or equivalent.
OUT	1/4" mono	1/4" phone jack, closed frame	Switchcraft 111X or equivalent.
DC	2.1mm	DC jack, 2.1mm panel mount	Mouser 163-4302-E or equivalent.
BATT	Battery snap	9V battery snap	Optional. Use the soft plastic type—the hard-shell type will not fit.
FSW	3PDT	Stomp switch, 3PDT	
ENC	125B	Enclosure, die-cast aluminum	Can also use a Hammond 1590N1.

BUILD NOTES

Clipping Switch

The clipping switch allows you select between different sets of diodes.

The downward position of the toggle switch is the stock RAT clipping arrangement, which has one silicon diode in each direction. The upward position of the toggle is two diodes in each direction, a higher clipping threshold with a more open sound. The center position leaves only the LEDs for a more dynamic and transparent tone.

If you look at the schematic, you'll see that the LEDs, D8 and D9, are always connected. However, in either the up or down switch positions, the lower-threshold diodes are engaged and so the LEDs have no effect—there's no signal left for them to clip.

Feel free to experiment, For example, you could jumper D7 for asymmetrical clipping. Or, you could omit the two clipping LEDs for a diode-lift mode in the center position.

Sweep Control

The Sweep knob (also called the “Ruetz mod” after [Philip Ruetz of Ruetz Amplification](#) who came up with it) puts some resistance in series with one of the low-end filters in the op-amp gain stage which changes the EQ and feel of the pedal.

While you can remove this control entirely by jumpering pins 1 and 2 of the pot, it's recommended to keep it because it's entirely out of the circuit when the knob is turned all the way down (full CCW).

SCHEMATIC

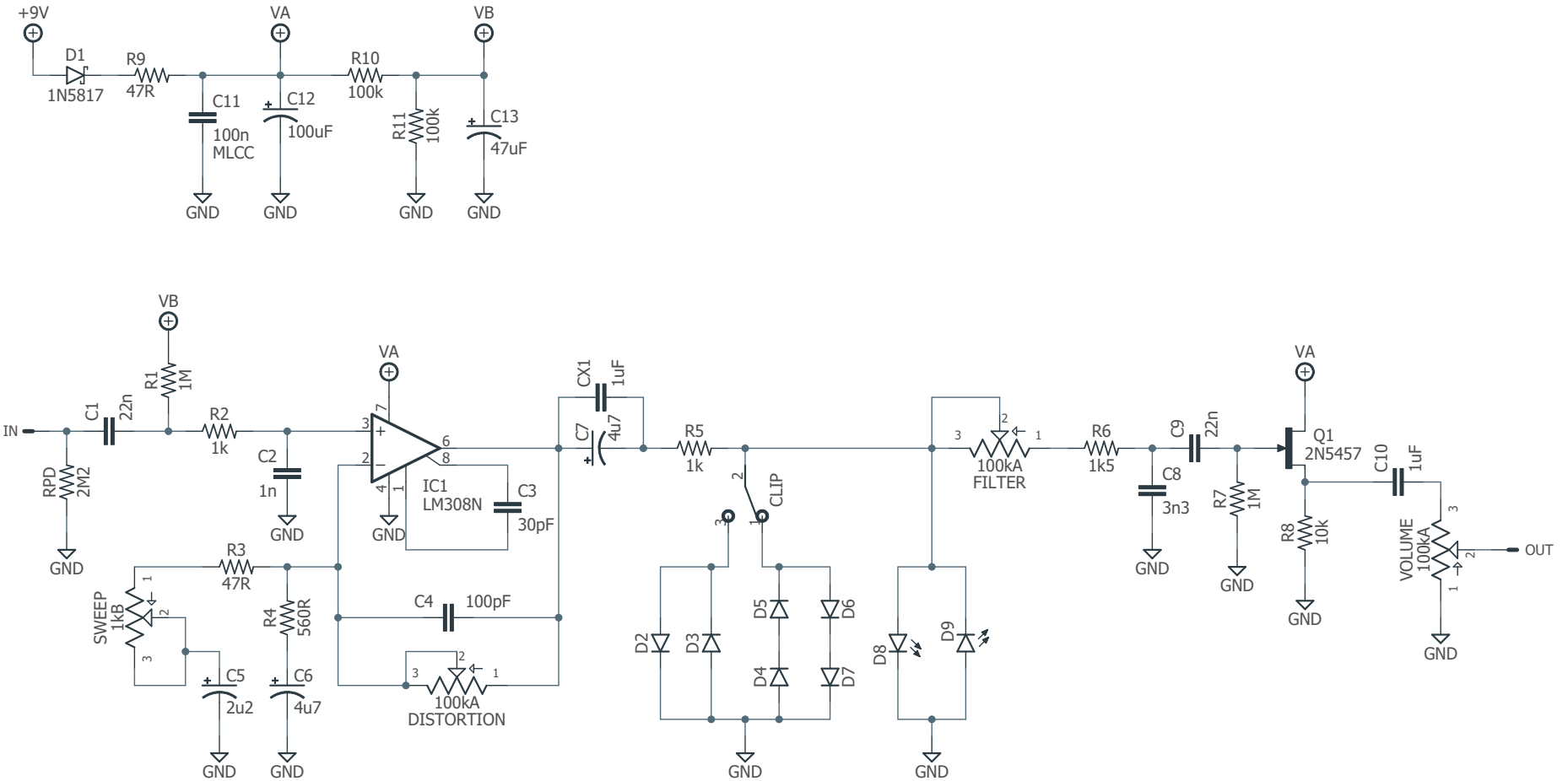

DRILL TEMPLATE

Cut out this drill template, fold the edges and tape it to the enclosure. Before drilling, it's recommended to first use a center punch for each of the holes to help guide the drill bit.

Ensure that this template is printed at 100% or "Actual Size". You can double-check this by measuring the scale on the printed page.

Top jack layout assumes the use of closed-frame jacks like the [Switchcraft 111X](#). If you'd rather use open-frame jacks, please refer to the Open-Frame Jack Drill Template for the top side.

LED hole drill size assumes the use of a [5mm LED bezel](#), available from several parts suppliers. Adjust size accordingly if using something different, such as a 3mm bezel, a plastic bezel, or just a plain LED.

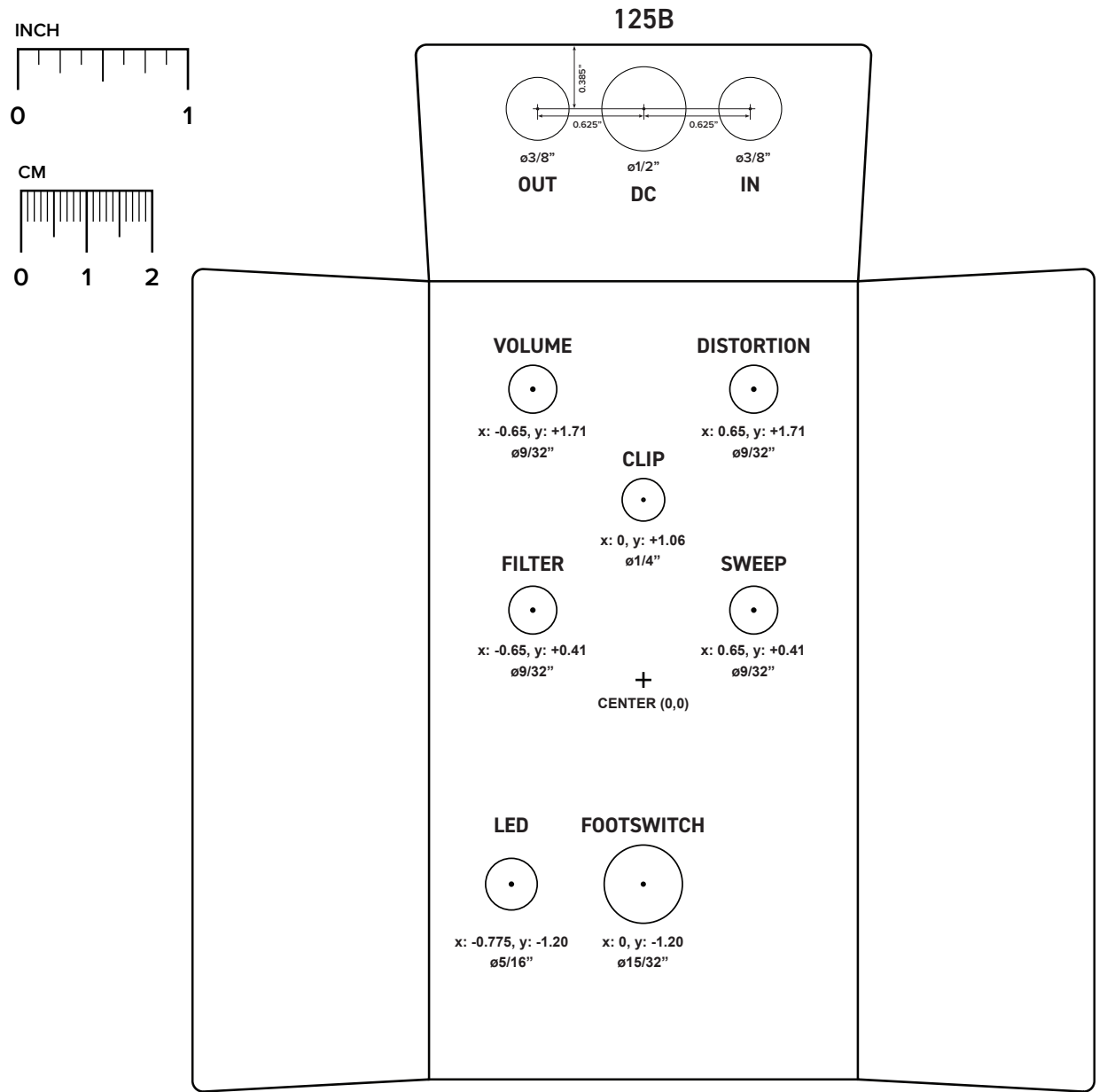

ENCLOSURE LAYOUT

Enclosure is shown without jacks. See next page for jack layout and wiring.

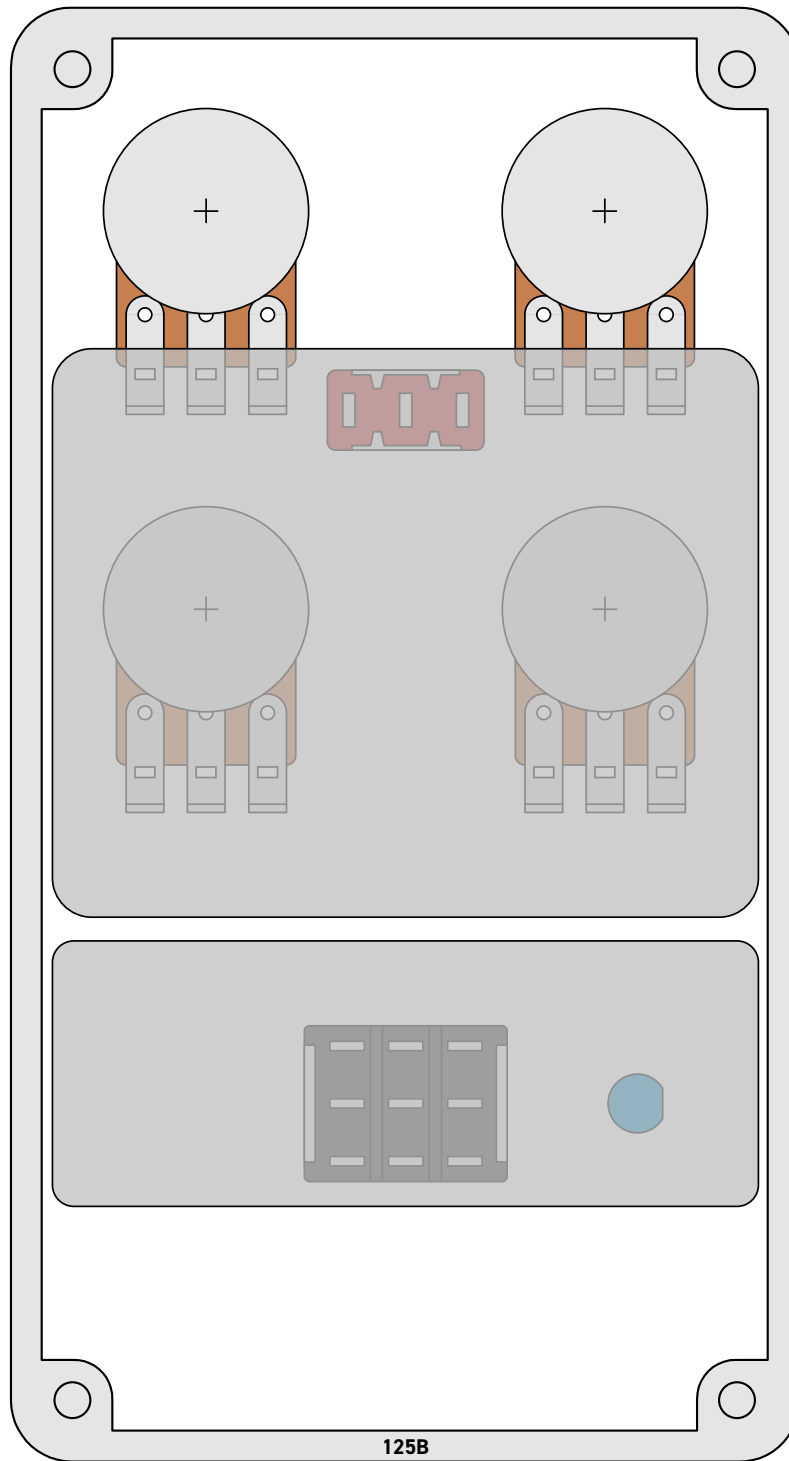

WIRING DIAGRAM

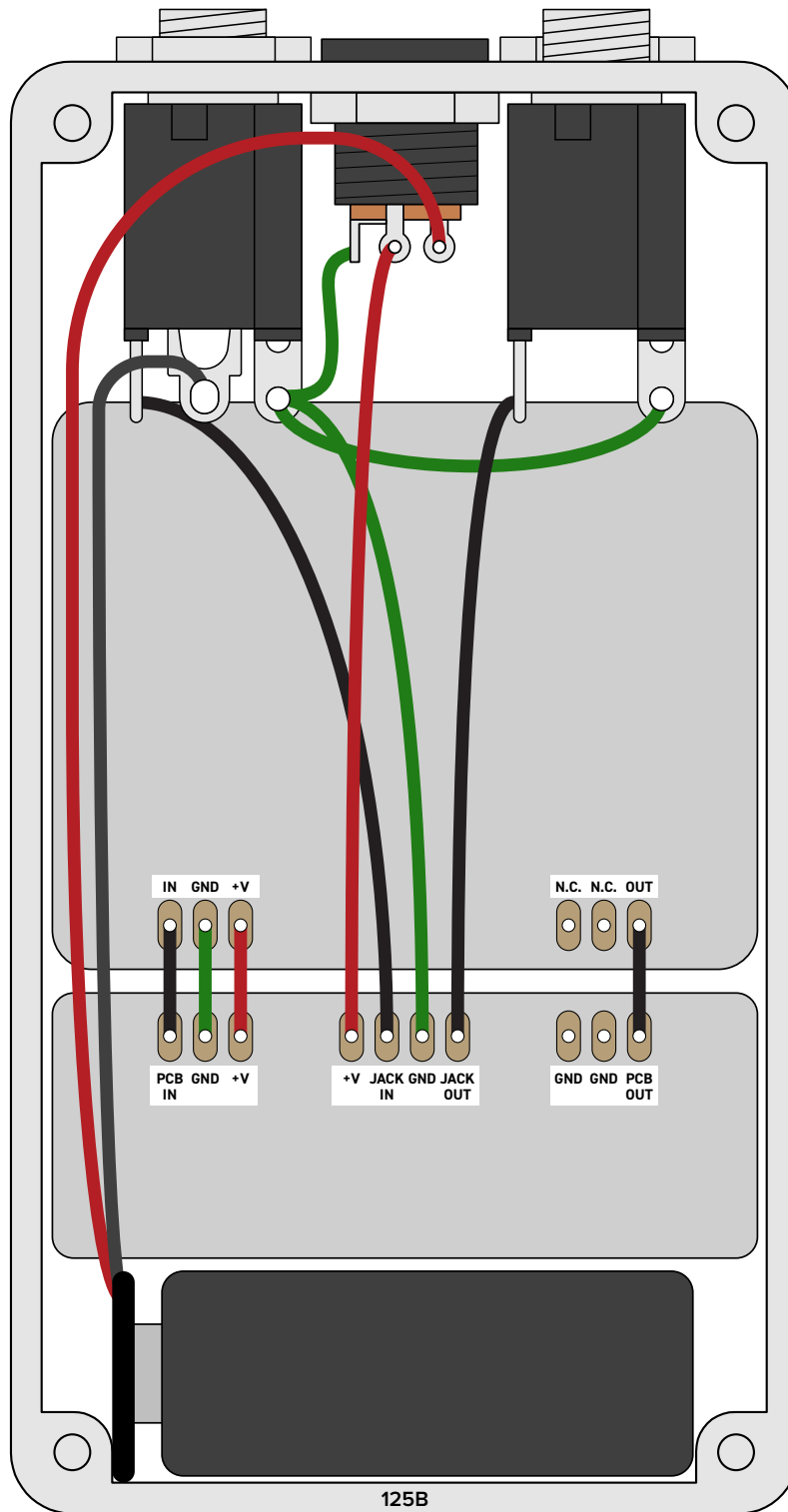

*Shown with optional 9V battery. If battery is omitted, both jacks can be mono rather than one being stereo.
Leave the far-right lug of the DC jack unconnected.*

LICENSE & USAGE

No direct support is offered for these projects beyond the provided documentation. It's assumed that you have at least some experience building pedals before starting one of these. Replacements and refunds cannot be offered unless it can be shown that the circuit or documentation are in error.

All of these circuits have been tested in good faith in their base configurations. However, not all the modifications or variations have necessarily been tested. These are offered only as suggestions based on the experience and opinions of others.

Projects may be used for commercial endeavors in any quantity unless specifically noted. No attribution is necessary, though a link back is always greatly appreciated. The only usage restrictions are that **(1) you cannot resell the PCB as part of a kit without prior arrangement, and (2) you cannot "goop" the circuit, scratch off the screenprint, or otherwise obfuscate the circuit to disguise its source.** (In other words: you don't have to go out of your way to advertise the fact that you use these PCBs, but please don't go out of your way to hide it. The guitar effects industry needs more transparency, not less!)

DOCUMENT REVISIONS

1.0.0 (2018-08-22)

Initial release.