

PROJECT NAME
NEXUS

BASED ON
Catalinbread Manx Loaghtan

BUILD DIFFICULTY
■■■■■ Easy

EFFECT TYPE
Distortion / Sustainer, Fuzz

DOCUMENT VERSION
1.0.0 (2019-03-14)

PROJECT SUMMARY

Based on the classic Big Muff circuit, this pedal switches out the original tone control with a 2-band Baxandall EQ, allowing control of both frequencies independently instead of just one or the other.

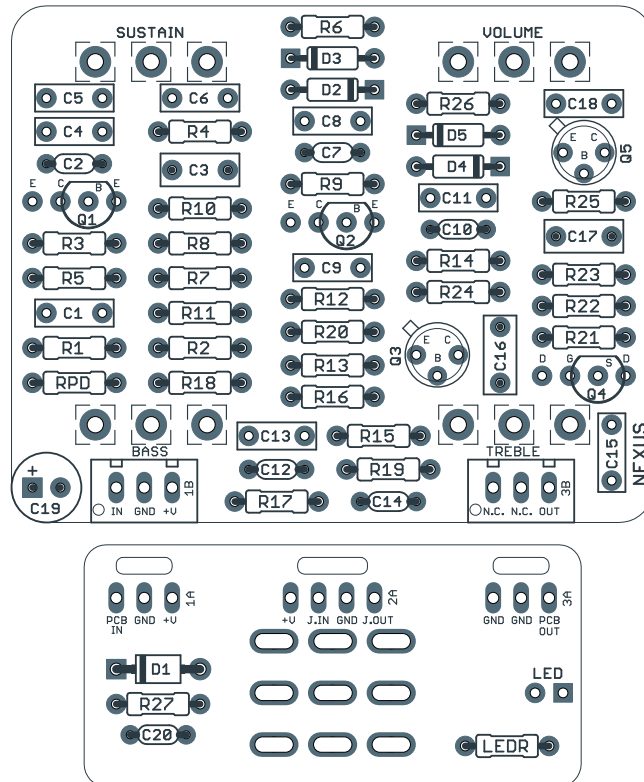

Actual size is 2.3" x 1.86" (main board) and 1.79" x 0.86" (bypass board).

TABLE OF CONTENTS

1	Project Overview	8	Enclosure Layout
2	Introduction & Usage	9	Wiring Diagram
3-5	Parts List	10	Licensing
6	Schematic	10	Document Revisions
7	Drill Template		

INTRODUCTION

The Nexus Distortion/Sustainer is based on the Catalinbread Manx Loaghtan, a mouthful of a pedal whose name is taken from a British breed of sheep native to the Isle of Man. This, of course, is a reference to the Big Muff and more specifically the Ram's Head.

As expected, the Manx Loaghtan shares a lot in common with the classic Big Muff topology, but with two notable changes that make it stand out.

First, the tone control has been replaced with a passive Baxandall tone control (also called a James tone stack) allowing independent adjustment of bass and treble frequencies. With the right settings, you can get a very close approximation of the mid-scoops of several different Muff variants, or you can come up with something entirely your own.

Second, a JFET-based gain recovery has been added to help counteract the ~20dB signal loss of the tone stack. This JFET stage is placed between the tone control and the stock Big Muff recovery stage (Q5 in this project).

USAGE

The Nexus has the following controls:

- **Sustain** controls the amount of drive or distortion, which also affects the amount of sustain.
- **Treble** and **Bass** form a Baxandall EQ allowing for adjustment of the respective frequencies.
- **Volume** is the overall output.

PARTS LIST

This parts list is also available in a spreadsheet format which can be imported directly into Mouser for easy parts ordering. Mouser doesn't carry all the parts (most notably potentiometers) so the second tab lists all the non-Mouser parts as well as sources for each.

[View parts list spreadsheet](#) →

PART	VALUE	TYPE	NOTES
R1	47k	Metal film resistor, 1/4W	
R2	100k	Metal film resistor, 1/4W	
R3	470k	Metal film resistor, 1/4W	
R4	130R	Metal film resistor, 1/4W	
R5	22k	Metal film resistor, 1/4W	
R6	1k	Metal film resistor, 1/4W	
R7	10k	Metal film resistor, 1/4W	
R8	470k	Metal film resistor, 1/4W	
R9	470k	Metal film resistor, 1/4W	
R10	130R	Metal film resistor, 1/4W	
R11	22k	Metal film resistor, 1/4W	
R12	10k	Metal film resistor, 1/4W	
R13	470k	Metal film resistor, 1/4W	
R14	470k	Metal film resistor, 1/4W	
R15	130R	Metal film resistor, 1/4W	
R16	22k	Metal film resistor, 1/4W	
R17	100k	Metal film resistor, 1/4W	
R18	2k2	Metal film resistor, 1/4W	
R19	100k	Metal film resistor, 1/4W	
R20	2M	Metal film resistor, 1/4W	
R21	2M	Metal film resistor, 1/4W	
R22	4k7	Metal film resistor, 1/4W	
R23	470k	Metal film resistor, 1/4W	
R24	100k	Metal film resistor, 1/4W	
R25	22k	Metal film resistor, 1/4W	
R26	2k2	Metal film resistor, 1/4W	
R27	47R	Metal film resistor, 1/4W	
RPD	2M2	Metal film resistor, 1/4W	
LEDR	4k7	Metal film resistor, 1/4W	

PARTS LIST, CONT.

PART	VALUE	TYPE	NOTES
C1	100n	Film capacitor, 7.2 x 2.5mm	
C2	omit	MLCC capacitor, NP0/COG	The original Manx Loaghtan had a space for C2, but nothing installed in it in production versions. This is a 470pF capacitor in the original Big Muff, so it has been included in this layout for experimentation purposes.
C3	470n	Film capacitor, 7.2 x 3mm	
C4	100n	Film capacitor, 7.2 x 2.5mm	
C5	1n	Film capacitor, 7.2 x 2.5mm	
C6	100n	Film capacitor, 7.2 x 2.5mm	
C7	470pF	MLCC capacitor, NP0/COG	
C8	100n	Film capacitor, 7.2 x 2.5mm	
C9	100n	Film capacitor, 7.2 x 2.5mm	
C10	470pF	MLCC capacitor, NP0/COG	
C11	100n	Film capacitor, 7.2 x 2.5mm	
C12	470pF	MLCC capacitor, NP0/COG	
C13	100n	Film capacitor, 7.2 x 2.5mm	
C14	470pF	MLCC capacitor, NP0/COG	
C15	4n7	Film capacitor, 7.2 x 2.5mm	
C16	470n	Film capacitor, 7.2 x 3mm	
C17	470n	Film capacitor, 7.2 x 3mm	
C18	100n	Film capacitor, 7.2 x 2.5mm	
C19	100uF	Electrolytic capacitor, 6.3mm	Power supply filter capacitor.
C20	100n	MLCC capacitor, X7R	Power supply filter capacitor.
D1	1N5817	Schottky diode, DO-41	
D2	1N914	Fast-switching diode, DO-35	
D3	1N914	Fast-switching diode, DO-35	
D4	1N914	Fast-switching diode, DO-35	
D5	1N914	Fast-switching diode, DO-35	
Q1	2N5088	BJT transistor, NPN, TO-92	
Q2	2N5088	BJT transistor, NPN, TO-92	
Q3	2N2222	BJT transistor, NPN, TO-18	
Q4	2N5457	JFET, N-channel, TO-92	Any general purpose JFET will be fine here (2N5458, MPF102).
Q5	2N2222	BJT transistor, NPN, TO-18	
SUS	100kA	16mm right-angle PCB mount pot	
BASS	500kA	16mm right-angle PCB mount pot	
TREB	500kB	16mm right-angle PCB mount pot	
VOL	100kA	16mm right-angle PCB mount pot	

PARTS LIST, CONT.

PART	VALUE	TYPE	NOTES
IN	1/4" stereo	1/4" phone jack, closed frame	Switchcraft 112BX or equivalent.
OUT	1/4" mono	1/4" phone jack, closed frame	Switchcraft 111X or equivalent.
DC	2.1mm	DC jack, 2.1mm panel mount	Mouser 163-4302-E or equivalent.
BATT	Battery snap	9V battery snap	Optional. Use the soft plastic type—the hard-shell type will not fit.
FSW	3PDT	Stomp switch, 3PDT	
ENC	125B	Enclosure, die-cast aluminum	Can also use a Hammond 1590N1.

SCHEMATIC

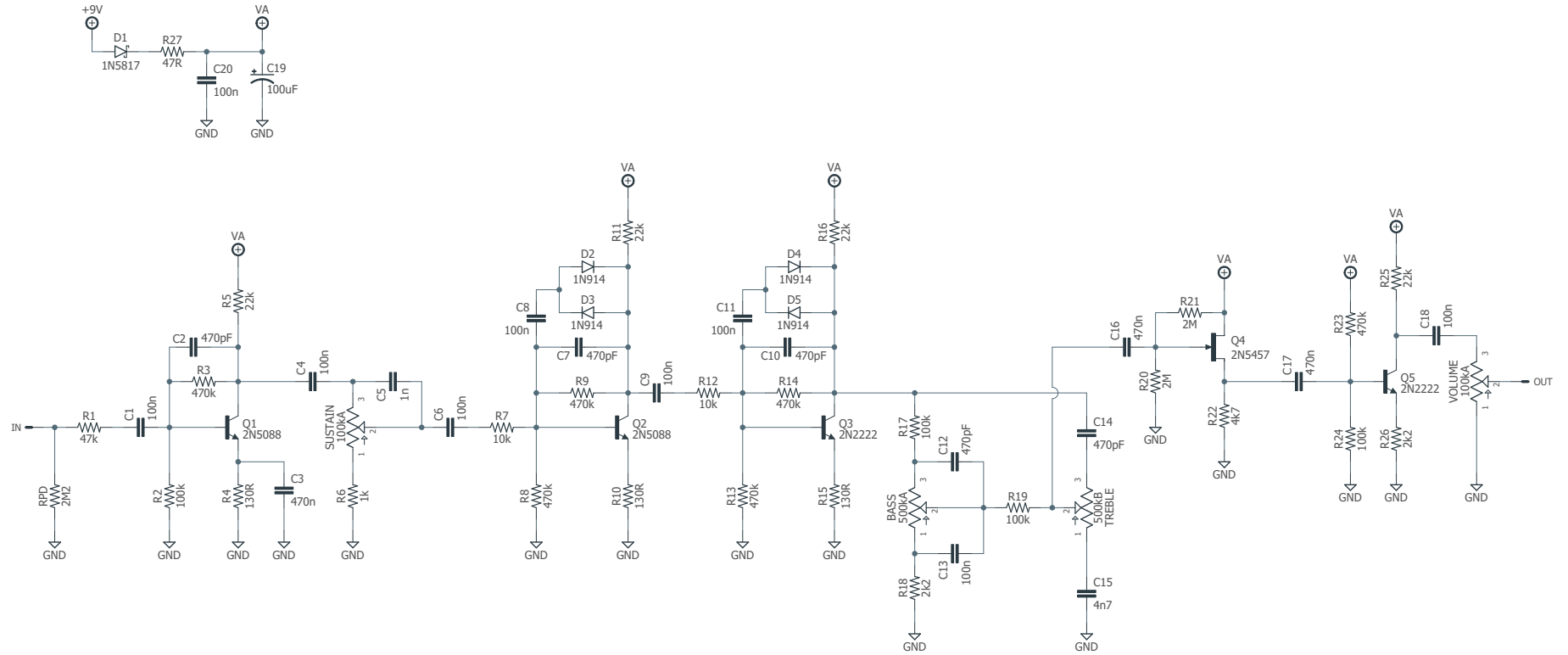

DRILL TEMPLATE

Cut out this drill template, fold the edges and tape it to the enclosure. Before drilling, it's recommended to first use a center punch for each of the holes to help guide the drill bit.

Ensure that this template is printed at 100% or "Actual Size". You can double-check this by measuring the scale on the printed page.

Top jack layout assumes the use of closed-frame jacks like the [Switchcraft 111X](#). If you'd rather use open-frame jacks, please refer to the Open-Frame Jack Drill Template for the top side.

LED hole drill size assumes the use of a [5mm LED bezel](#), available from several parts suppliers. Adjust size accordingly if using something different, such as a 3mm bezel, a plastic bezel, or just a plain LED.

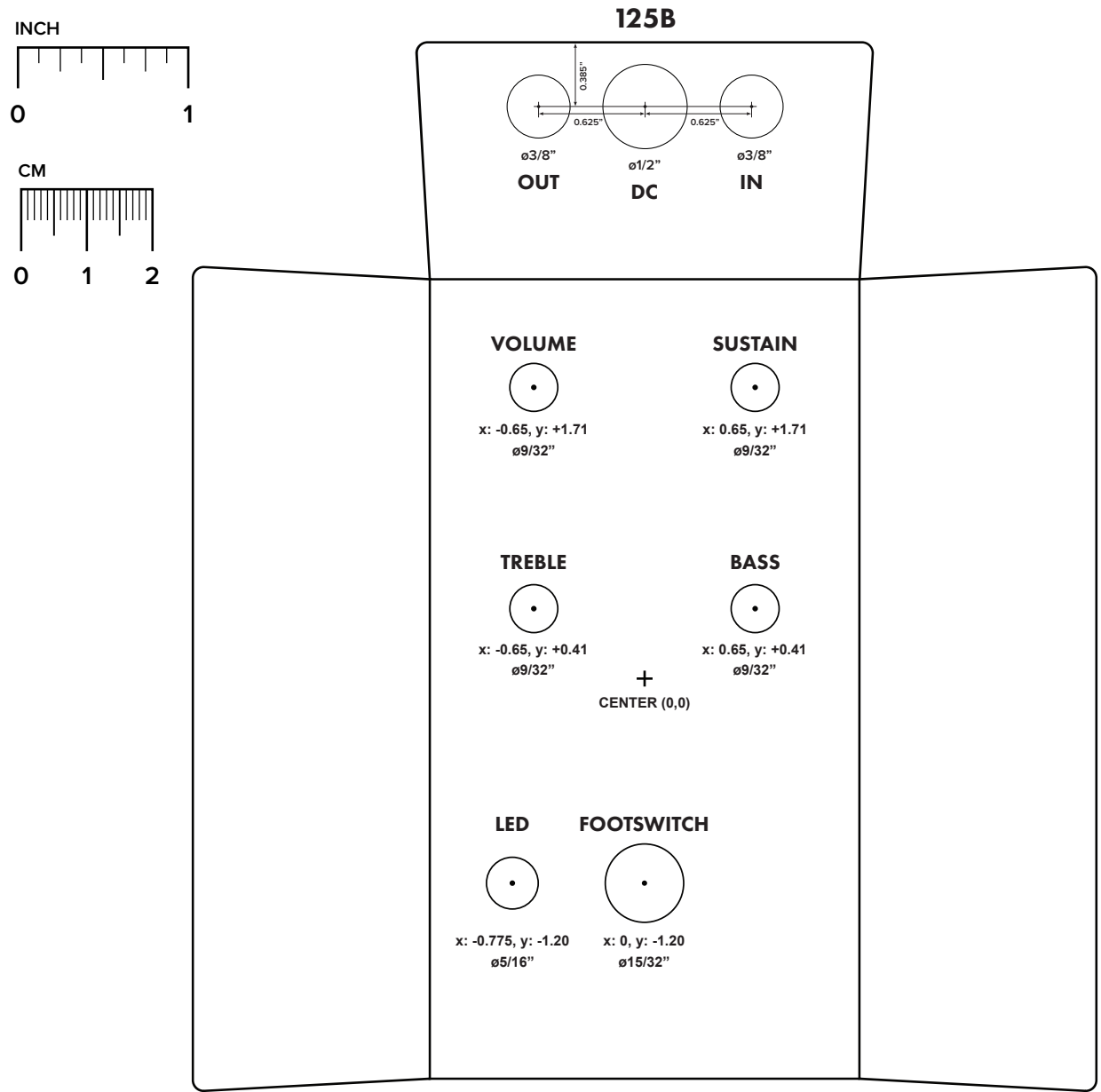

ENCLOSURE LAYOUT

Enclosure is shown without jacks. See next page for jack layout and wiring.

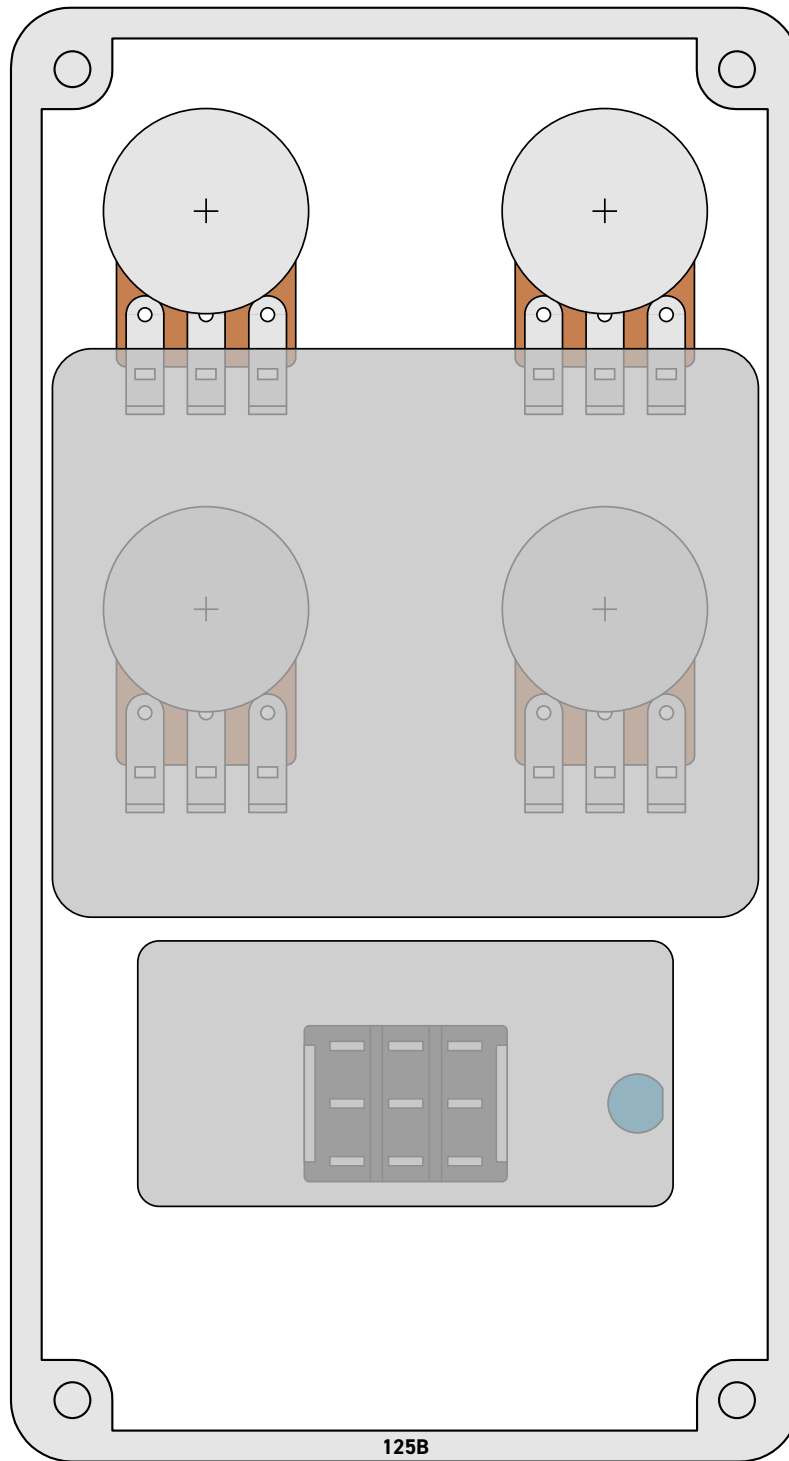

WIRING DIAGRAM

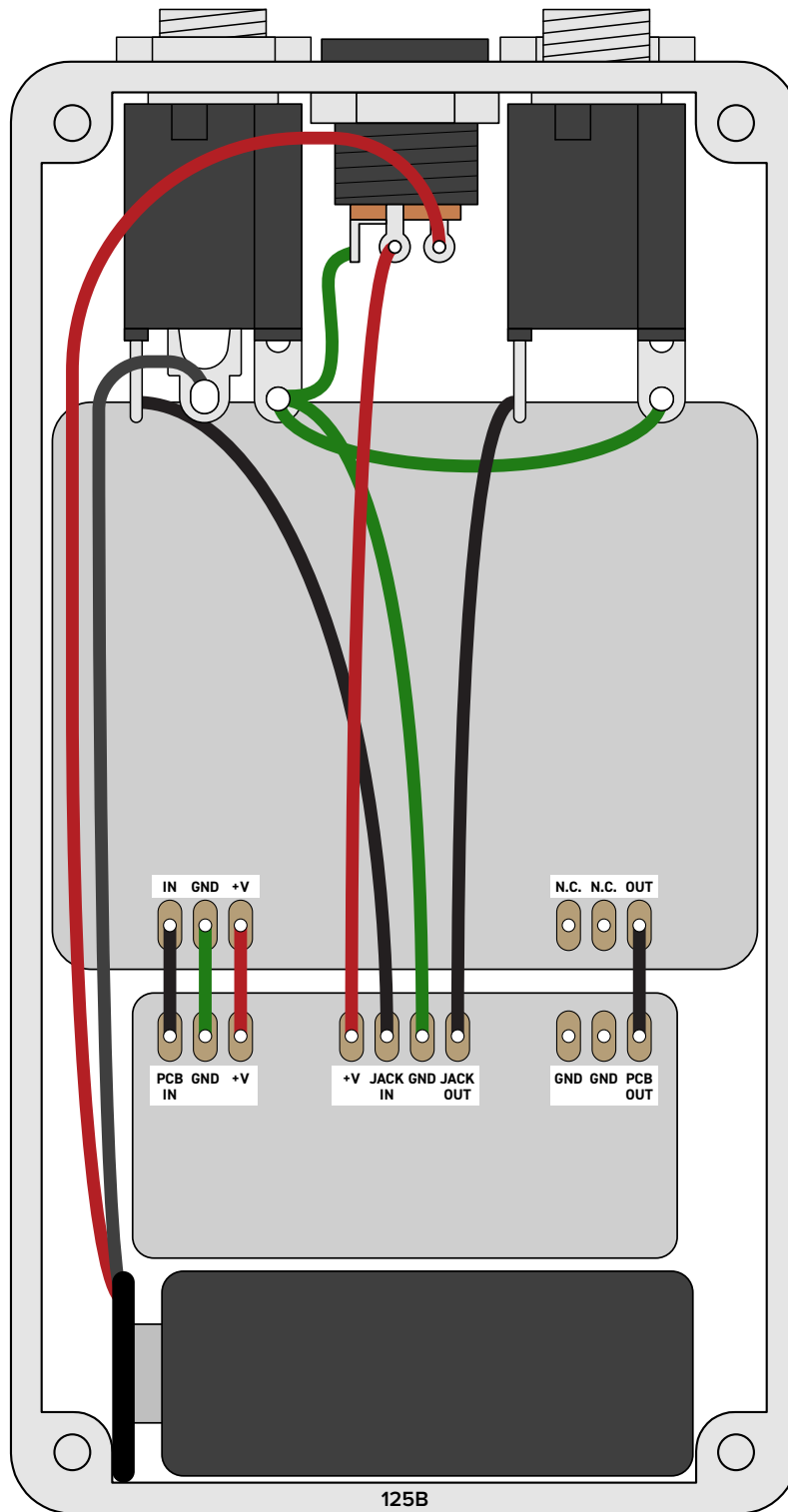

*Shown with optional 9V battery. If battery is omitted, both jacks can be mono rather than one being stereo.
Leave the far-right lug of the DC jack unconnected.*

LICENSE & USAGE

No direct support is offered for these projects beyond the provided documentation. It's assumed that you have at least some experience building pedals before starting one of these. Replacements and refunds cannot be offered unless it can be shown that the circuit or documentation are in error.

All of these circuits have been tested in good faith in their base configurations. However, not all the modifications or variations have necessarily been tested. These are offered only as suggestions based on the experience and opinions of others.

Projects may be used for commercial endeavors in any quantity unless specifically noted. No attribution is necessary, though a link back is always greatly appreciated. The only usage restrictions are that **(1) you cannot resell the PCB as part of a kit without prior arrangement, and (2) you cannot "goop" the circuit, scratch off the screenprint, or otherwise obfuscate the circuit to disguise its source.** (In other words: you don't have to go out of your way to advertise the fact that you use these PCBs, but please don't go out of your way to hide it. The guitar effects industry needs more transparency, not less!)

DOCUMENT REVISIONS

1.0.0 (2019-03-14)

Initial release.