

PROJECT NAME

OSIRIS



BASED ON

Black Arts Toneworks Pharaoh

BUILD DIFFICULTY



EFFECT TYPE

Distortion / Sustainer, Fuzz

DOCUMENT VERSION

1.0.0 (2019-03-14)

PROJECT SUMMARY

Based on the classic Big Muff circuit, this pedal adds a high/low impedance switch, a diode selector switch, and a high-end control inside the tone stack.

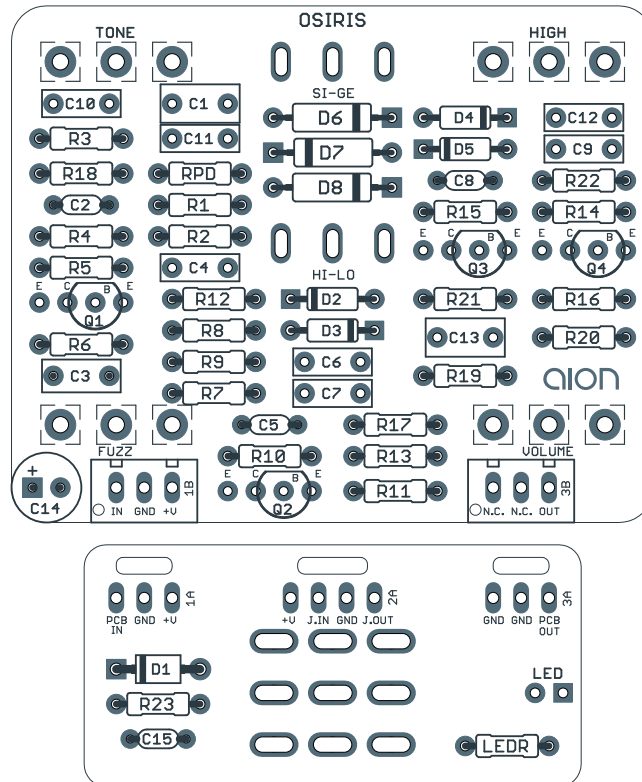

Actual size is 2.3" x 1.86" (main board) and 1.79" x 0.86" (bypass board).

TABLE OF CONTENTS

1	Project Overview	7	Enclosure Layout
2	Introduction & Usage	8	Wiring Diagram
3-4	Parts List	9	Licensing
5	Schematic	9	Document Revisions
6	Drill Template		

INTRODUCTION

The Osiris Distortion/Sustainer is adapted from the Black Arts Toneworks Pharaoh Fuzz, a Big Muff-based circuit with a few modifications.

First, an input impedance switch has been added to the front of the circuit. By reducing the signal level before the boost and clipping stages, you can match it to high-output instruments or earlier pedals in the chain, or just reduce the overall signal level for more headroom and less clipping.

Second, a clipping switch has been added to control has been added to go between silicon and germanium diodes in the second clipping stage. The silicon diodes are in the stock Big Muff for a familiar sound, while germaniums will be more compressed and gainy, but also softer with a more rounded clipping waveform.

Third, a “High” control has been added to the bass side of the tone control rotation allowing the low-pass filter frequency to be adjusted. This restores some of the high end so you don’t have to choose between a bass emphasis and treble emphasis.

USAGE

The Osiris has the following controls:

- **Hi/Lo** toggles between two different resistors on the input, which changes the amount of headroom and clipping later in the circuit.
- **Si/Ge** toggles between silicon (stock) diodes and asymmetrical germanium diodes.
- **Sustain** controls the amount of drive or distortion, which also affects the amount of sustain.
- **Tone** is a the classic Big Muff balance control with a high-pass filter (treble emphasis) on one side and a low-pass filter (bass emphasis) on the other.
- **High** allows you to vary the low-pass filter cutoff point on the bass side of the tone control, restoring some of the high-end signal on the bass settings.
- **Volume** is the overall output.

PARTS LIST

This parts list is also available in a spreadsheet format which can be imported directly into Mouser for easy parts ordering. Mouser doesn't carry all the parts (most notably potentiometers) so the second tab lists all the non-Mouser parts as well as sources for each.

[View parts list spreadsheet](#) →

PART	VALUE	TYPE	NOTES
R1	39k	Metal film resistor, 1/4W	
R2	390k	Metal film resistor, 1/4W	
R3	100k	Metal film resistor, 1/4W	
R4	470k	Metal film resistor, 1/4W	
R5	1k	Metal film resistor, 1/4W	
R6	10k	Metal film resistor, 1/4W	
R7	1k	Metal film resistor, 1/4W	
R8	6k2	Metal film resistor, 1/4W	
R9	100k	Metal film resistor, 1/4W	
R10	470k	Metal film resistor, 1/4W	
R11	100R	Metal film resistor, 1/4W	
R12	10k	Metal film resistor, 1/4W	
R13	6k2	Metal film resistor, 1/4W	
R14	100k	Metal film resistor, 1/4W	
R15	470k	Metal film resistor, 1/4W	
R16	100R	Metal film resistor, 1/4W	
R17	10k	Metal film resistor, 1/4W	
R18	470k	Metal film resistor, 1/4W	
R19	470k	Metal film resistor, 1/4W	
R20	100k	Metal film resistor, 1/4W	
R21	10k	Metal film resistor, 1/4W	
R22	2k2	Metal film resistor, 1/4W	
R23	47R	Metal film resistor, 1/4W	
RPD	2M2	Metal film resistor, 1/4W	Input pulldown resistor. Can be as low as 1M.
LEDR	4k7	Metal film resistor, 1/4W	LED current-limiting resistor. Adjust value to change LED brightness.
C1	1uF	Film capacitor, 7.2 x 3.5mm	
C2	470pF	MLCC capacitor, NP0/COG	
C3	470n	Film capacitor, 7.2 x 3mm	
C4	47n	Film capacitor, 7.2 x 2.5mm	
C5	470pF	MLCC capacitor, NP0/COG	

PARTS LIST, CONT.

PART	VALUE	TYPE	NOTES
C6	47n	Film capacitor, 7.2 x 2.5mm	
C7	47n	Film capacitor, 7.2 x 2.5mm	
C8	470pF	MLCC capacitor, NP0/COG	
C9	47n	Film capacitor, 7.2 x 2.5mm	
C10	10n	Film capacitor, 7.2 x 2.5mm	
C11	22n	Film capacitor, 7.2 x 2.5mm	
C12	47n	Film capacitor, 7.2 x 2.5mm	
C13	1uF	Film capacitor, 7.2 x 3.5mm	
C14	100uF	Electrolytic capacitor, 6.3mm	Power supply filter capacitor.
C15	100n	MLCC capacitor, X7R	Power supply filter capacitor.
D1	1N5817	Schottky diode, DO-41	
D2	1N914	Fast-switching diode, DO-35	
D3	1N914	Fast-switching diode, DO-35	
D4	1N914	Fast-switching diode, DO-35	
D5	1N914	Fast-switching diode, DO-35	
D6	1N34A	Germanium diode	Exact part number is unimportant. Any germanium should work here.
D7	1N34A	Germanium diode	Exact part number is unimportant. Any germanium should work here.
D8	1N34A	Germanium diode	Exact part number is unimportant. Any germanium should work here.
Q1	MPSA18	BJT transistor, NPN, TO-92	
Q2	2N5089	BJT transistor, NPN, TO-92	
Q3	2N5089	BJT transistor, NPN, TO-92	
Q4	2N5089	BJT transistor, NPN, TO-92	
HI-LO	SPDT	Toggle switch, SPDT on-on	
SI-GE	SPDT	Toggle switch, SPDT on-on	
FUZZ	100kB	16mm right-angle PCB mount pot	
HIGH	25kB	16mm right-angle PCB mount pot	
TONE	250kB	16mm right-angle PCB mount pot	
VOL.	100kA	16mm right-angle PCB mount pot	
IN	1/4" stereo	1/4" phone jack, closed frame	Switchcraft 112BX or equivalent.
OUT	1/4" mono	1/4" phone jack, closed frame	Switchcraft 111X or equivalent.
DC	2.1mm	DC jack, 2.1mm panel mount	Mouser 163-4302-E or equivalent.
BATT	Battery snap	9V battery snap	Optional. Use the soft plastic type—the hard-shell type will not fit.
FSW	3PDT	Stomp switch, 3PDT	
ENC	125B	Enclosure, die-cast aluminum	Can also use a Hammond 1590N1.

SCHEMATIC

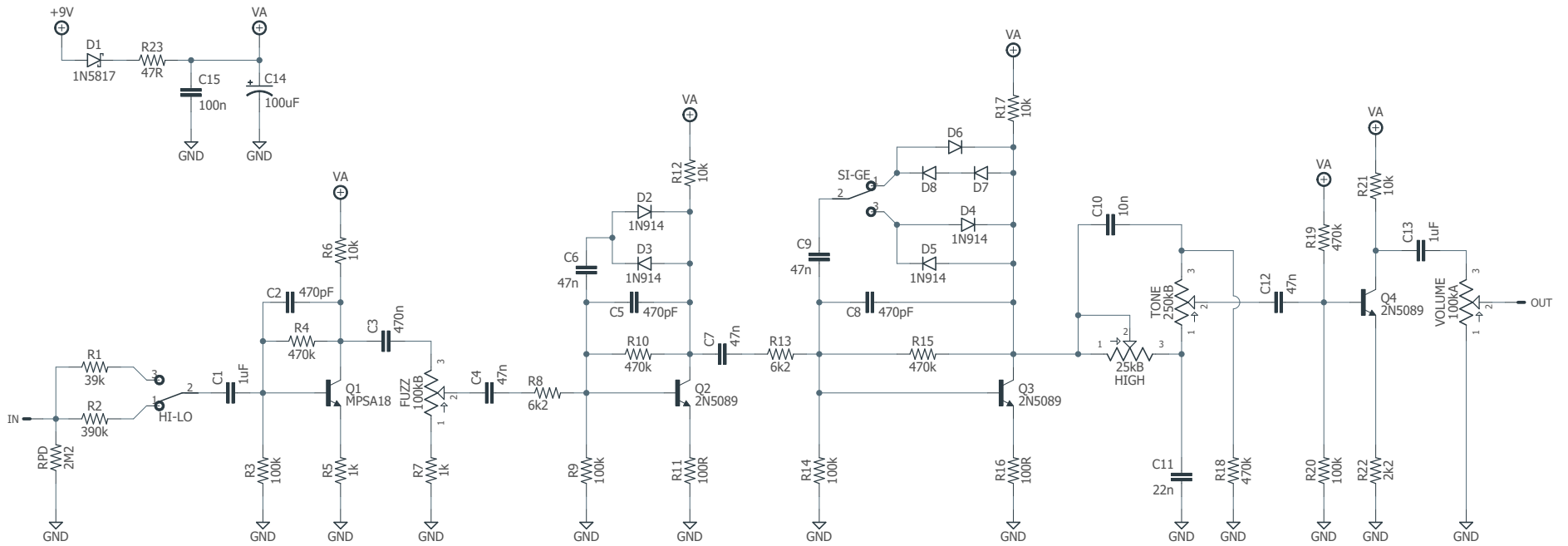

DRILL TEMPLATE

Cut out this drill template, fold the edges and tape it to the enclosure. Before drilling, it's recommended to first use a center punch for each of the holes to help guide the drill bit.

Ensure that this template is printed at 100% or "Actual Size". You can double-check this by measuring the scale on the printed page.

Top jack layout assumes the use of closed-frame jacks like the [Switchcraft 111X](#). If you'd rather use open-frame jacks, please refer to the Open-Frame Jack Drill Template for the top side.

LED hole drill size assumes the use of a [5mm LED bezel](#), available from several parts suppliers. Adjust size accordingly if using something different, such as a 3mm bezel, a plastic bezel, or just a plain LED.

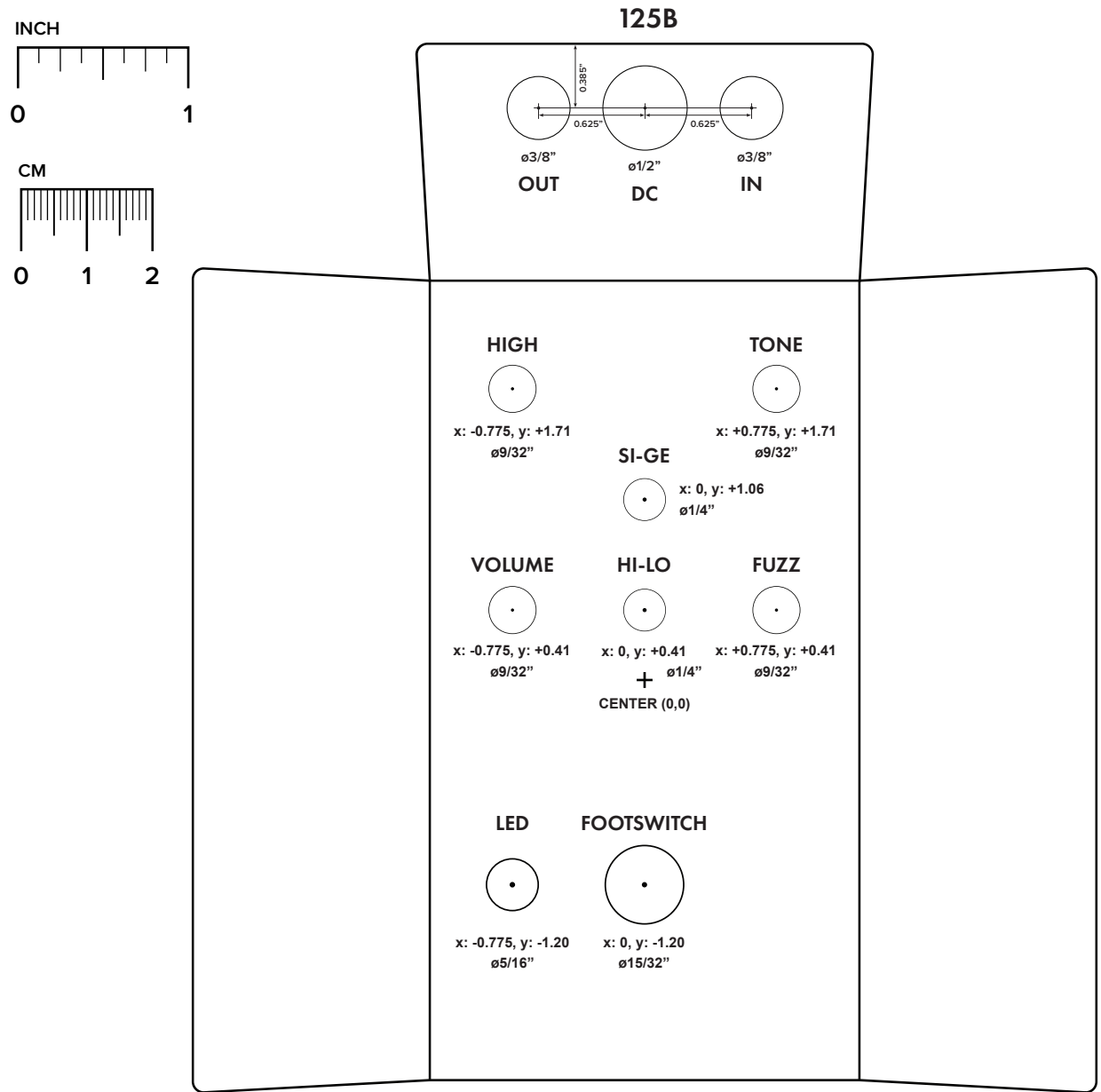

ENCLOSURE LAYOUT

Enclosure is shown without jacks. See next page for jack layout and wiring.

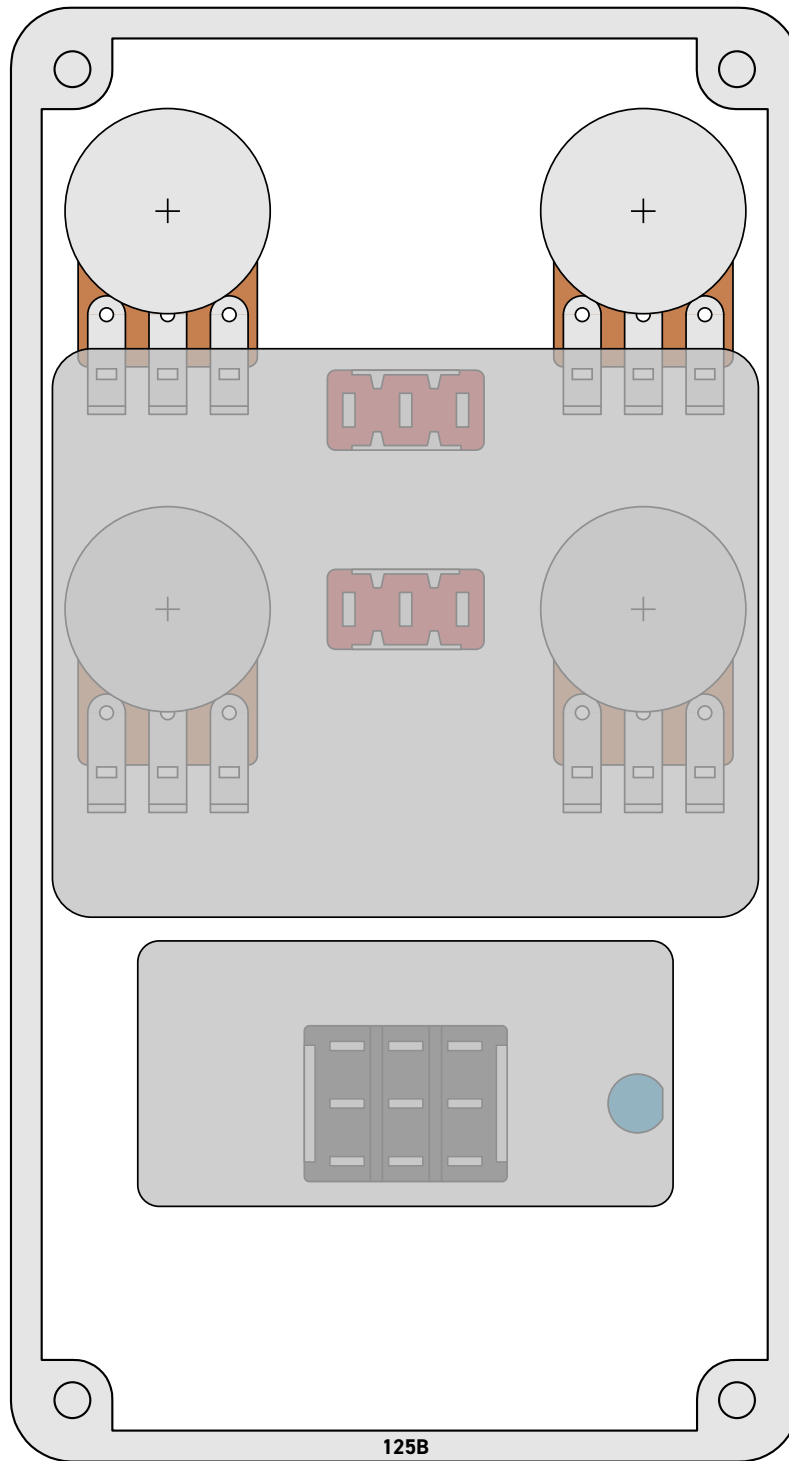

WIRING DIAGRAM

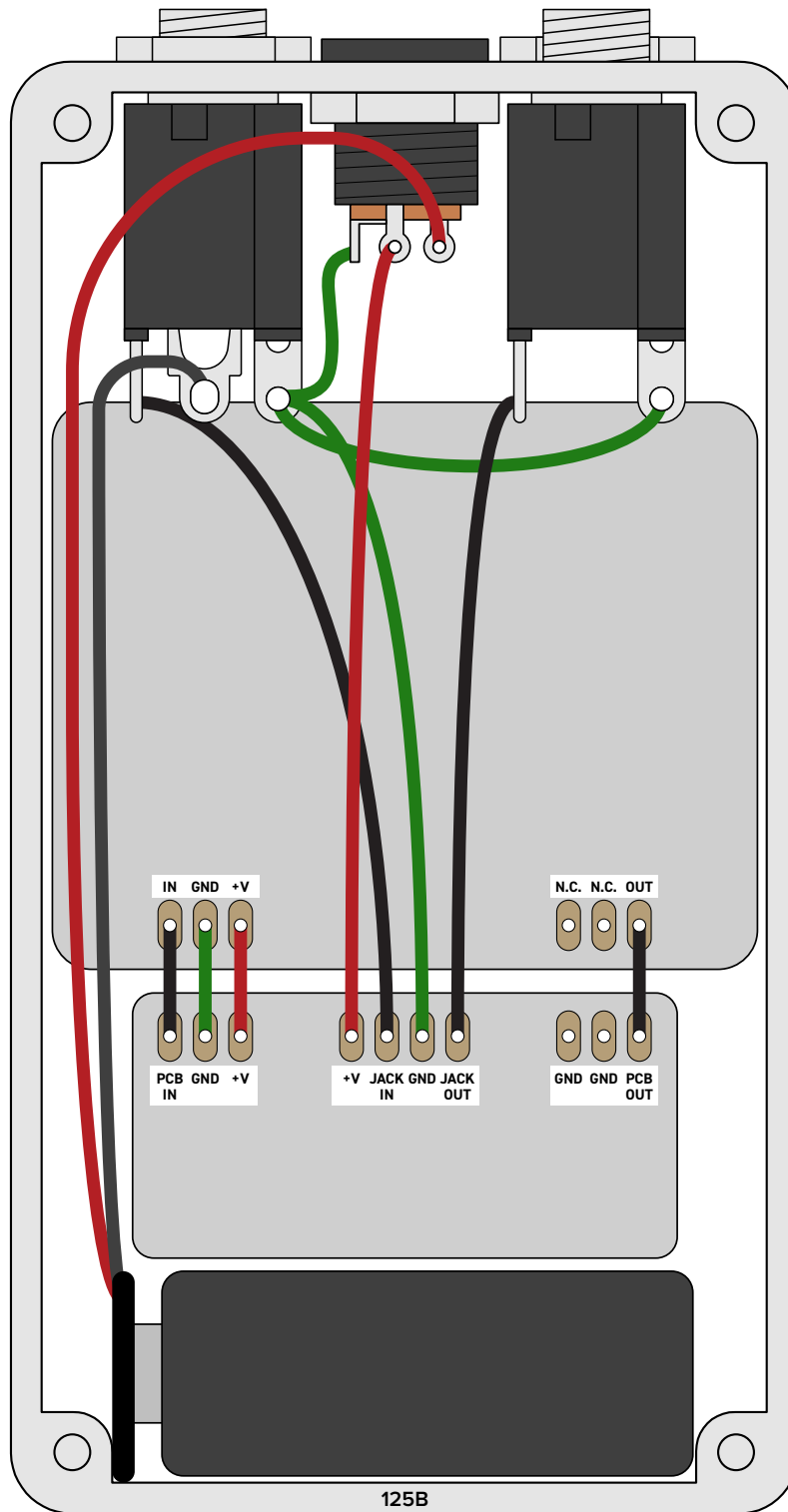

*Shown with optional 9V battery. If battery is omitted, both jacks can be mono rather than one being stereo.
Leave the far-right lug of the DC jack unconnected.*

LICENSE & USAGE

No direct support is offered for these projects beyond the provided documentation. It's assumed that you have at least some experience building pedals before starting one of these. Replacements and refunds cannot be offered unless it can be shown that the circuit or documentation are in error.

All of these circuits have been tested in good faith in their base configurations. However, not all the modifications or variations have necessarily been tested. These are offered only as suggestions based on the experience and opinions of others.

Projects may be used for commercial endeavors in any quantity unless specifically noted. No attribution is necessary, though a link back is always greatly appreciated. The only usage restrictions are that **(1) you cannot resell the PCB as part of a kit without prior arrangement, and (2) you cannot "goop" the circuit, scratch off the screenprint, or otherwise obfuscate the circuit to disguise its source.** (In other words: you don't have to go out of your way to advertise the fact that you use these PCBs, but please don't go out of your way to hide it. The guitar effects industry needs more transparency, not less!)

DOCUMENT REVISIONS

1.0.0 (2019-03-14)

Initial release.