

PROJECT NAME

# CHARON



BASED ON

Ibanez CR5 Crunchy Rhythm

BUILD DIFFICULTY

■■■■□ Intermediate

EFFECT TYPE

Overdrive

DOCUMENT VERSION

1.0.0 (2019-08-04)

## PROJECT SUMMARY

An under-appreciated Ibanez drive pedal originally marketed toward rhythm guitarists, but versatile enough for a wide range of applications.

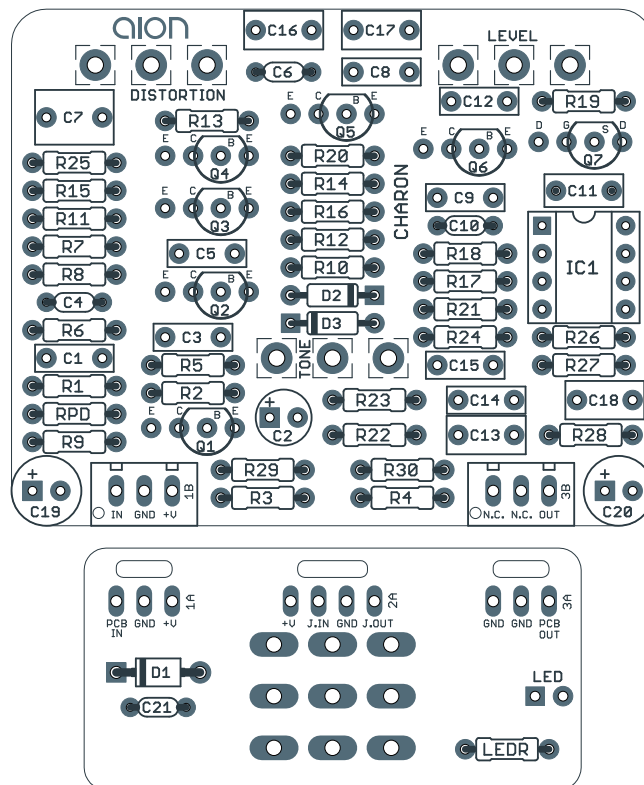

*Actual size is 2.3" x 1.86" (main board) and 1.79" x 0.86" (bypass board).*

# TABLE OF CONTENTS

---

1	Project Overview	8	Enclosure Layout
2	Introduction & Usage	9	Wiring Diagram
3-5	Parts List	10	Licensing
6	Schematic	10	Document Revisions
7	Drill Template		

## INTRODUCTION

---

The Charon Overdrive is a clone of the Ibanez CR5 Crunchy Rhythm, an overlooked gem in the Ibanez pantheon of the 1980s and early '90s. Released in 1989 as part of the original Soundtank series, the CR5 was produced up until the second series launched in 1992.

The drive section of the CR5 is very similar to the earlier DS-10 Distortion Charger from 1986. It uses a differential transistor pair in place of an op-amp for the initial gain stage. This is sort of a low-tech op-amp in the sense that the gain can be adjusted with a potentiometer in the feedback loop. While Boss uses differentials in a handful of circuits such as the BD-2 and OD-3, these are the only two Ibanez circuits with a differential pair in place of an op-amp.

Following the differential stage, signal is hard-clipped via diodes to ground. This is where the similarities with the DS-10 end. From here, it passes into an op-amp stage that boosts bass at around 108 Hz to add back some low-end. After this, there's a basic hi-cut tone control, volume control, and output buffer.

The Charon is a part-for-part recreation of the CR5 circuit with no modifications, except that the pinout of the transistors has been changed to the USA E-B-C convention (2N3904, 2N5088).

## USAGE

---

The Charon has the following controls:

- **Distortion** controls the amount of gain in the differential amplifier stage.
- **Tone** controls the treble response of the effect.
- **Level** controls the overall output.

## PARTS LIST

This parts list is also available in a spreadsheet format which can be imported directly into Mouser for easy parts ordering. Mouser doesn't carry all the parts—notably potentiometers—so the second tab lists all the non-Mouser parts as well as sources for each.

[View parts list spreadsheet](#) →

PART	VALUE	TYPE	NOTES
C1	100n	Film capacitor, 7.2 x 2.5mm	
C2	10uF	Electrolytic capacitor, 5mm	
C3	47n	Film capacitor, 7.2 x 2.5mm	
C4	220pF	MLCC capacitor, NP0/COG	
C5	47n	Film capacitor, 7.2 x 2.5mm	
C6	47pF	MLCC capacitor, NP0/COG	
C7	2.2uF	Film capacitor, 7.2 x 5mm	
C8	22n	Film capacitor, 7.2 x 2.5mm	
C9	100n	Film capacitor, 7.2 x 2.5mm	
C10	100pF	MLCC capacitor, NP0/COG	
C11	470n	Film capacitor, 7.2 x 3mm	
C12	68n	Film capacitor, 7.2 x 2.5mm	
C13	1uF	Film capacitor, 7.2 x 3.5mm	
C14	3n3	Film capacitor, 7.2 x 2.5mm	
C15	22n	Film capacitor, 7.2 x 2.5mm	
C16	1uF	Film capacitor, 7.2 x 3.5mm	
C17	1uF	Film capacitor, 7.2 x 3.5mm	
C18	1uF	Film capacitor, 7.2 x 3.5mm	
C19	100uF	Electrolytic capacitor, 6.3mm	
C20	47uF	Electrolytic capacitor, 5mm	
C21	100n	MLCC capacitor, X7R	
R1	1k	Metal film resistor, 1/4W	
R2	510k	Metal film resistor, 1/4W	
R3	9k1	Metal film resistor, 1/4W	
R4	22k	Metal film resistor, 1/4W	
R5	10k	Metal film resistor, 1/4W	
R6	100k	Metal film resistor, 1/4W	
R7	100k	Metal film resistor, 1/4W	
R8	220R	Metal film resistor, 1/4W	
R9	10k	Metal film resistor, 1/4W	

## PARTS LIST, CONT.

PART	VALUE	TYPE	NOTES
R10	100k	Metal film resistor, 1/4W	
R11	4k7	Metal film resistor, 1/4W	
R12	10k	Metal film resistor, 1/4W	
R13	10k	Metal film resistor, 1/4W	
R14	10k	Metal film resistor, 1/4W	
R15	4k7	Metal film resistor, 1/4W	
R16	22k	Metal film resistor, 1/4W	
R17	1M	Metal film resistor, 1/4W	
R18	3k	Metal film resistor, 1/4W	
R19	820R	Metal film resistor, 1/4W	
R20	10k	Metal film resistor, 1/4W	
R21	82k	Metal film resistor, 1/4W	
R22	510k	Metal film resistor, 1/4W	
R23	2k4	Metal film resistor, 1/4W	
R24	1M	Metal film resistor, 1/4W	
R25	10k	Metal film resistor, 1/4W	
R26	510k	Metal film resistor, 1/4W	
R27	470R	Metal film resistor, 1/4W	
R28	100k	Metal film resistor, 1/4W	
R29	10k	Metal film resistor, 1/4W	
R30	10k	Metal film resistor, 1/4W	
RPD	2M2	Metal film resistor, 1/4W	
LEDR	4k7	Metal film resistor, 1/4W	
D1	1N5817	Schottky diode, DO-41	
D2	1N914	Fast-switching diode, DO-35	
D3	1N914	Fast-switching diode, DO-35	
Q1	2N5088	BJT transistor, NPN, TO-92	Original uses 2SC1815GR. Can sub 2N3904.
Q2	2N3906	BJT transistor, PNP, TO-92	Original uses 2SC1815Y. Can sub 2N5088.
Q3	2N5087	BJT transistor, PNP, TO-92	Original uses 2SA1015GR. Can sub 2N3906.
Q4	2N5087	BJT transistor, PNP, TO-92	Original uses 2SA1015GR. Can sub 2N3906.
Q5	2N3906	BJT transistor, PNP, TO-92	Original uses 2SC1815Y. Can sub 2N5088.
Q6	2N3906	BJT transistor, PNP, TO-92	Original uses 2SC1815Y. Can sub 2N5088.
Q7	2N5457	JFET, N-channel, TO-92	Original uses 2SK1180.
IC1	JRC4558D	Operational amplifier, DIP8	
IC1-S	DIP-8 socket	IC socket, DIP-8	

## PARTS LIST, CONT.

PART	VALUE	TYPE	NOTES
DIST.	100k $\Omega$	Potentiometer, 16mm right-angle	
TONE	50k $\Omega$	Potentiometer, 16mm right-angle	
VOL.	100k $\Omega$	Potentiometer, 16mm right-angle	
LED	5mm	LED, 5mm, red diffused	
IN	1/4" stereo	1/4" phone jack, closed frame	Switchcraft 112BX or equivalent.
OUT	1/4" mono	1/4" phone jack, closed frame	Switchcraft 111X or equivalent.
DC	2.1mm	DC jack, 2.1mm panel mount	Mouser 163-4302-E or equivalent.
BATT	Battery snap	9V battery snap	Optional. Use the soft plastic type—the hard-shell type will not fit.
FSW	3PDT	Stomp switch, 3PDT	
ENC	125B	Enclosure, die-cast aluminum	Can also use a Hammond 1590N1.

# SCHEMATIC

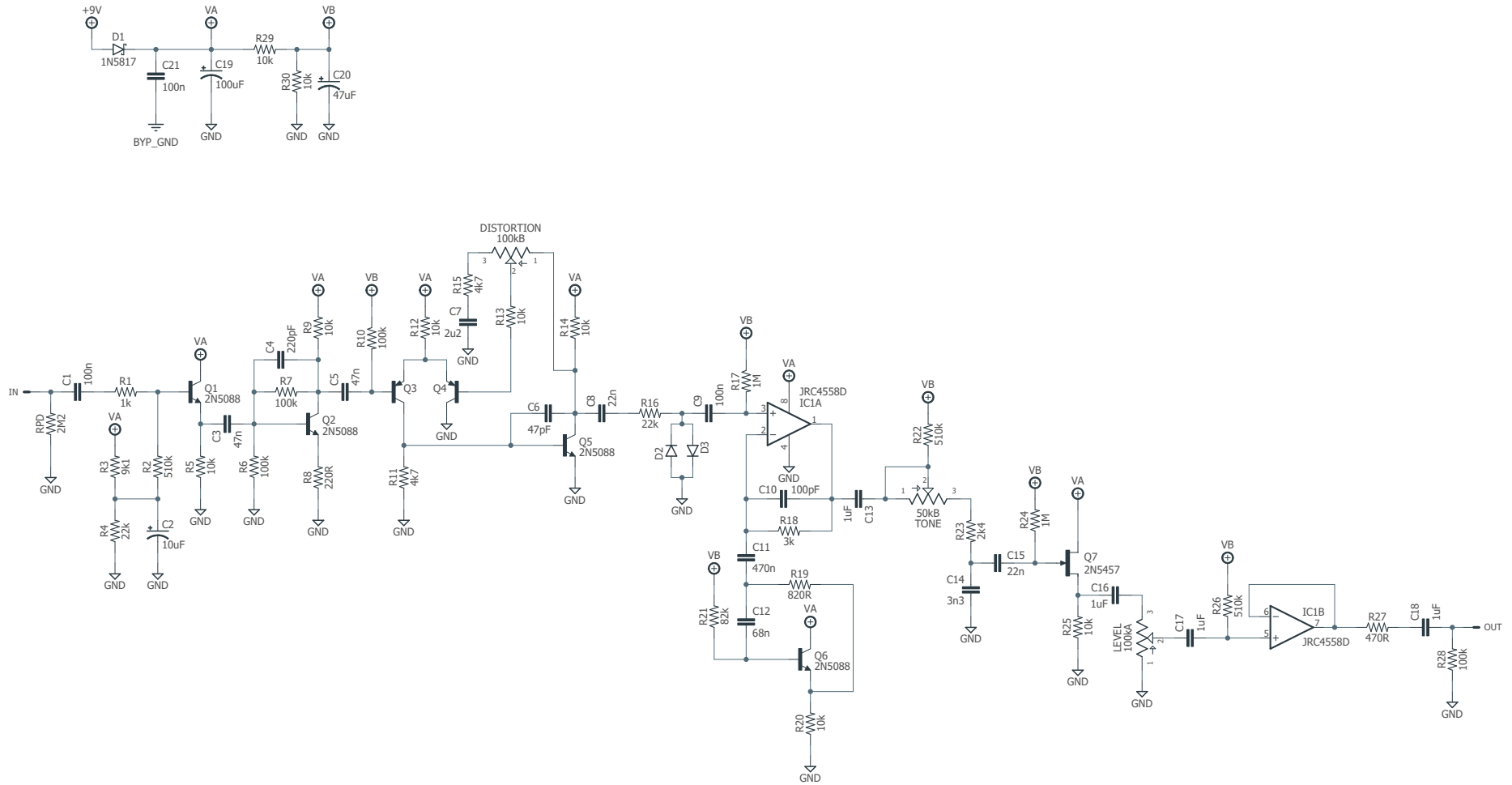

# DRILL TEMPLATE

Cut out this drill template, fold the edges and tape it to the enclosure. Before drilling, it's recommended to first use a center punch for each of the holes to help guide the drill bit.

Ensure that this template is printed at 100% or "Actual Size". You can double-check this by measuring the scale on the printed page.

**Top jack layout** assumes the use of closed-frame jacks like the [Switchcraft 111X](#). If you'd rather use open-frame jacks, please refer to the Open-Frame Jack Drill Template for the top side.

**LED hole drill size** assumes the use of a [5mm LED bezel](#), available from several parts suppliers. Adjust size accordingly if using something different, such as a 3mm bezel, a plastic bezel, or just a plain LED.

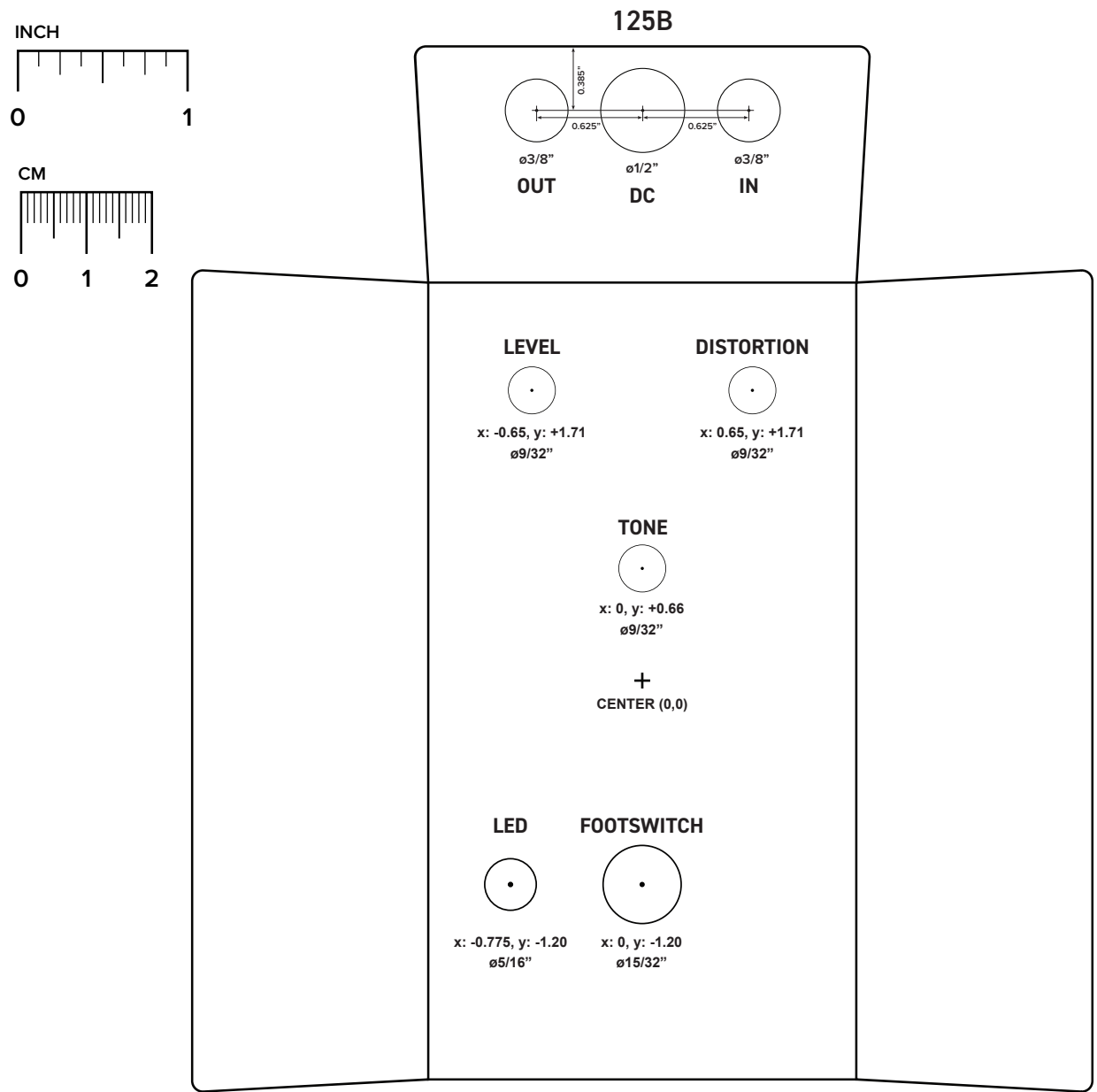

# ENCLOSURE LAYOUT

---

Enclosure is shown without jacks. See next page for jack layout and wiring.

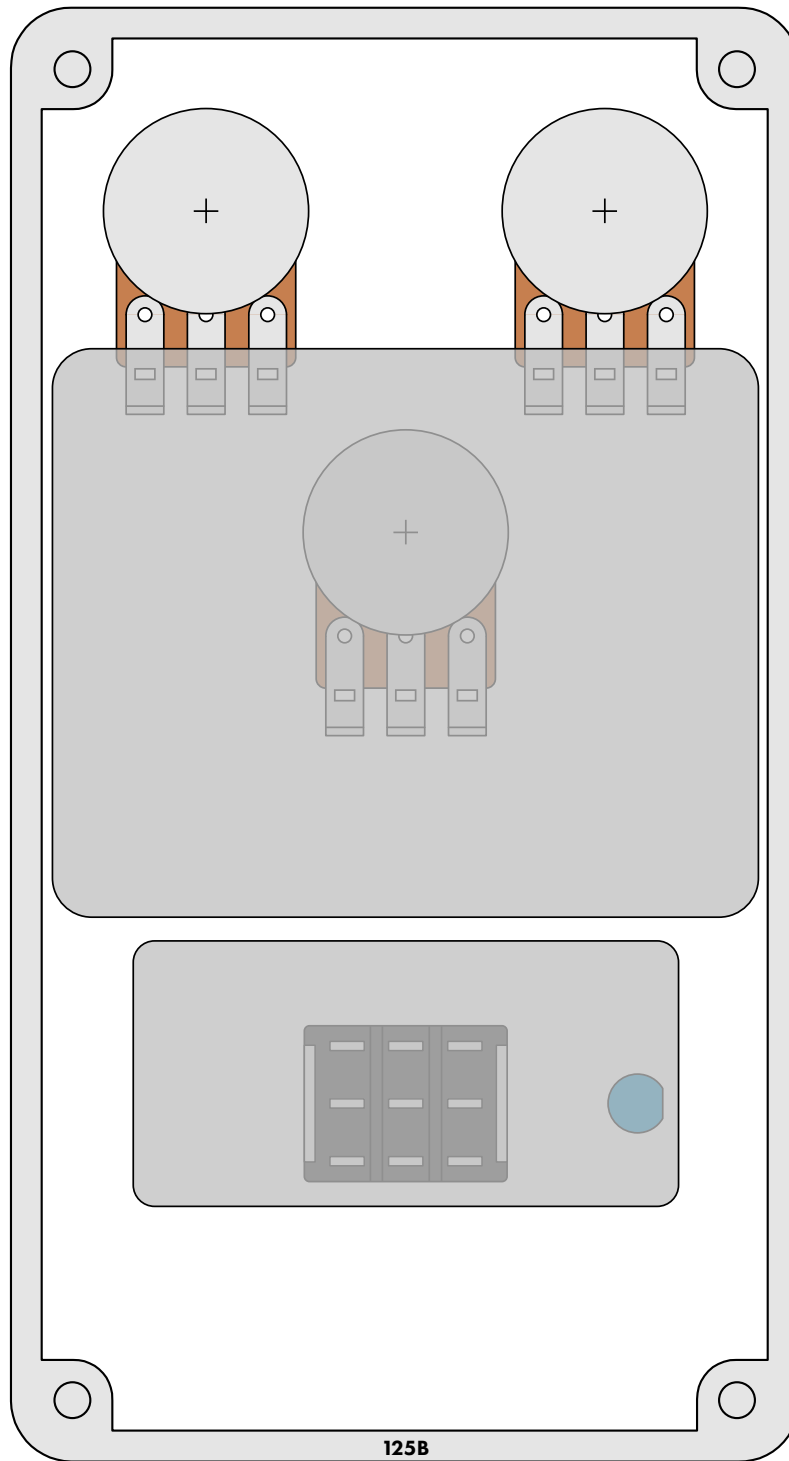



# WIRING DIAGRAM

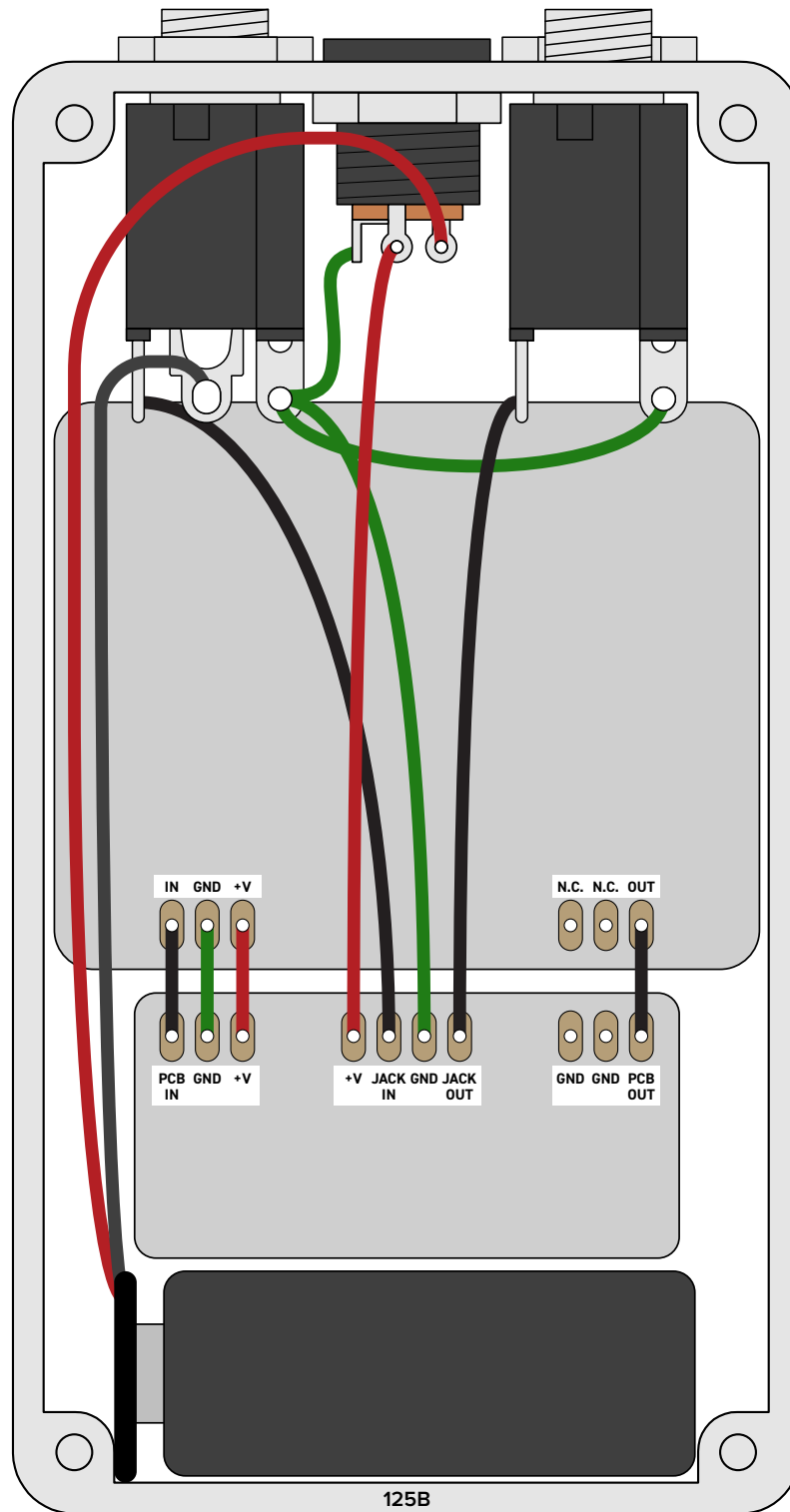

*Shown with optional 9V battery. If battery is omitted, both jacks can be mono rather than one being stereo.  
Leave the far-right lug of the DC jack unconnected.*

## LICENSE & USAGE

---

**No direct support is offered for these projects beyond the provided documentation.** It's assumed that you have at least some experience building pedals before starting one of these. Replacements and refunds cannot be offered unless it can be shown that the circuit or documentation are in error.

**All of these circuits have been tested in good faith in their base configurations.** However, not all the modifications or variations have necessarily been tested. These are offered only as suggestions based on the experience and opinions of others.

**Projects may be used for commercial endeavors in any quantity** unless specifically noted. No attribution is necessary, though a link back is always greatly appreciated. The only usage restrictions are that **(1) you cannot resell the PCB as part of a kit without prior arrangement, and (2) you cannot "goop" the circuit, scratch off the screenprint, or otherwise obfuscate the circuit to disguise its source.** (In other words: you don't have to go out of your way to advertise the fact that you use these PCBs, but please don't go out of your way to hide it. The guitar effects industry needs more transparency, not less!)

## DOCUMENT REVISIONS

---

### 1.0.0 (2019-08-04)

Initial release.