

PROJECT NAME

PENUMBRA

BASED ON

Zvex Woolly Mammoth / Mastotron

BUILD DIFFICULTY

■■■■■ Easy

EFFECT TYPE

Bass fuzz

DOCUMENT VERSION

1.0.0 (2019-08-31)

PROJECT SUMMARY

A full-frequency silicon fuzz, originally designed for bass but just as suited for guitar. Famously used by Chris Wolstenholme of Muse.

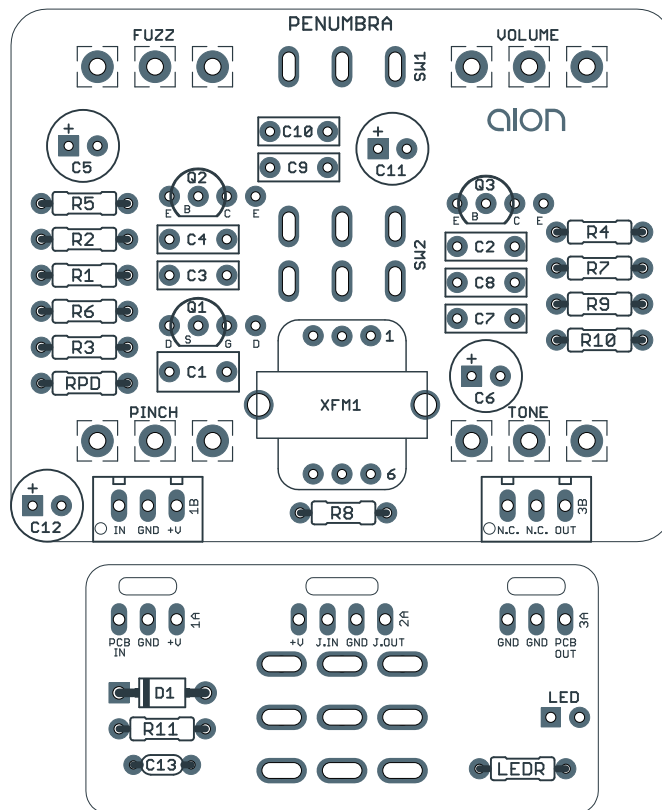

Actual size is 2.3" x 1.86" (main board) and 1.78" x 0.86" (bypass board).

TABLE OF CONTENTS

1	Project Overview	7	Drill Template
2	Introduction & Usage	8	Enclosure Layout
3-4	Parts List	9	Wiring Diagram
5	Build Notes	10	Licensing
6	Schematic	10	Document Revisions

INTRODUCTION

The Penumbra Bass Fuzz is inspired by the Zvex Woolly Mammoth and Mastotron, taking elements from each but with some modifications for better usability.

The Woolly Mammoth is a full-frequency fuzz with no low-end cut, making it great for bass, but of course it works great on guitar as well. It features controls for fuzz level, EQ, pinch (pulse width of the wave form) and output volume. The Mastotron added a few controls but is otherwise identical.

The Penumbra is a combination of the two, including the Subs (Low) toggle but not the “Relax / Push” control. This has been replaced by a transformer-based pickup simulator, [originally designed by Jack Orman of AMZ](#) and used by others including Earthquaker Devices in their Erupter pedal.

Like many vintage fuzz circuits, the Woolly Mammoth works best when it’s the first pedal after the guitar. If its input signal is too low-impedance (i.e. coming from a buffer or an active pedal), it can drastically change the character of the effect. The pickup simulator will convert any input impedance into the impedance of a guitar pickup, so the Penumbra will behave as it should no matter where it’s placed in the chain.

This pickup simulator is on a toggle switch, allowing it to be easily bypassed. This way you can leave it off if the Mammoth is the first pedal in the chain. When the pickup simulator is turned off, the Penumbra is sonically identical to the original Woolly Mammoth / Mastotron circuit.

USAGE

The Penumbra has the following controls:

- **Fuzz** sets the amount of transistor gain and thus the fuzz level of the effect.
- **Pinch** changes the pulse width of the waveform, from symmetrical square wave on the left, to asymmetrical on the right. It also affects the amount of gating.
- **Tone** allows the high-end to be tweaked without sacrificing the bass frequencies.
- **Volume** is the output volume control.
- **Low** is a 3-position toggle that changes the output capacitor, which controls the bass EQ.
- **Pickup** is a pickup simulator that allows the Penumbra to be used anywhere in the effects chain.

PARTS LIST

This parts list is also available in a spreadsheet format which can be imported directly into Mouser for easy parts ordering. Mouser doesn't carry all the parts—most notably potentiometers—so the second tab lists all the non-Mouser parts as well as sources for each.

[View parts list spreadsheet](#) →

PART	VALUE	TYPE	NOTES
R1	1M	Metal film resistor, 1/4W	
R2	1M	Metal film resistor, 1/4W	
R3	1M	Metal film resistor, 1/4W	
R4	1k	Metal film resistor, 1/4W	
R5	56k	Metal film resistor, 1/4W	
R6	1k	Metal film resistor, 1/4W	
R7	2k2	Metal film resistor, 1/4W	
R8	22k	Metal film resistor, 1/4W	
R9	10k	Metal film resistor, 1/4W	
R10	5k1	Metal film resistor, 1/4W	
R11	100R	Metal film resistor, 1/4W	
RPD	2M2	Metal film resistor, 1/4W	
LEDR	4k7	Metal film resistor, 1/4W	
C1	1uF	Film capacitor, 7.2 x 3.5mm	
C2	1n	Film capacitor, 7.2 x 2.5mm	
C3	220n	Film capacitor, 7.2 x 2.5mm	
C4	10n	Film capacitor, 7.2 x 2.5mm	
C5	100uF	Electrolytic capacitor, 6.3mm	
C6	100uF	Electrolytic capacitor, 6.3mm	
C7	10n	Film capacitor, 7.2 x 2.5mm	
C8	220n	Film capacitor, 7.2 x 2.5mm	
C9	33n	Film capacitor, 7.2 x 2.5mm	
C10	68n	Film capacitor, 7.2 x 2.5mm	
C11	100uF	Electrolytic capacitor, 6.3mm	
C12	100uF	Electrolytic capacitor, 6.3mm	
C13	100n	MLCC capacitor, X7R	
D1	1N5817	Schottky diode, DO-41	
Q1	2N5457	JFET, N-channel, TO-92	Any general purpose JFET should be fine here (2N5458, MPF102).
Q2	2N3904	BJT transistor, NPN, TO-92	
Q3	2N3904	BJT transistor, NPN, TO-92	

PARTS LIST, CONT.

PART	VALUE	TYPE	NOTES
XFM1	42TL019	Transformer, audio, 10KCT/600CT	Mouser 42TL019-RC
FUZZ	5kC	16mm right-angle PCB mount pot	
PINCH	500kB	16mm right-angle PCB mount pot	
TONE	10kB	16mm right-angle PCB mount pot	
VOL.	10kB	16mm right-angle PCB mount pot	
SW1	SPDT cntr off	Toggle switch, SPDT on-off-on	
SW2	DPDT on-on	Toggle switch, DPDT on-on	
LED	5mm	LED, 5mm, red diffused	
IN	1/4" stereo	1/4" phone jack, closed frame	Switchcraft 112BX or equivalent.
OUT	1/4" mono	1/4" phone jack, closed frame	Switchcraft 111X or equivalent.
DC	2.1mm	DC jack, 2.1mm panel mount	Mouser 163-4302-E or equivalent.
BATT	Battery snap	9V battery snap	Optional. Use the soft plastic type—the hard-shell type will not fit.
FSW	3PDT	Stomp switch, 3PDT	
ENC	125B	Enclosure, die-cast aluminum	Can also use a Hammond 1590N1.

BUILD NOTES

Transformer orientation

The 42TM019 transformer is symmetrical, so it can be inadvertently installed backwards, which would give it the wrong coil resistance for the pickup simulation.

Pin 1 and 6 are marked on the PCB. The side with pin 1 corresponds to the primary coil, which is marked “P” on the transformer. So in other words, the side marked “P” should be facing toward the SW2 pads.

Bypassing the transformer

With the toggle switch in the “off” position, the transformer is fully out of the circuit. But, if you’re not able to source the transformer or just don’t want to use it, you can leave it off entirely.

Jumper the two center pads of the toggle switch together (pads 2 and 6) and omit the following parts:

- C1-2
- R1-4
- Q1
- XFM1

SCHEMATIC

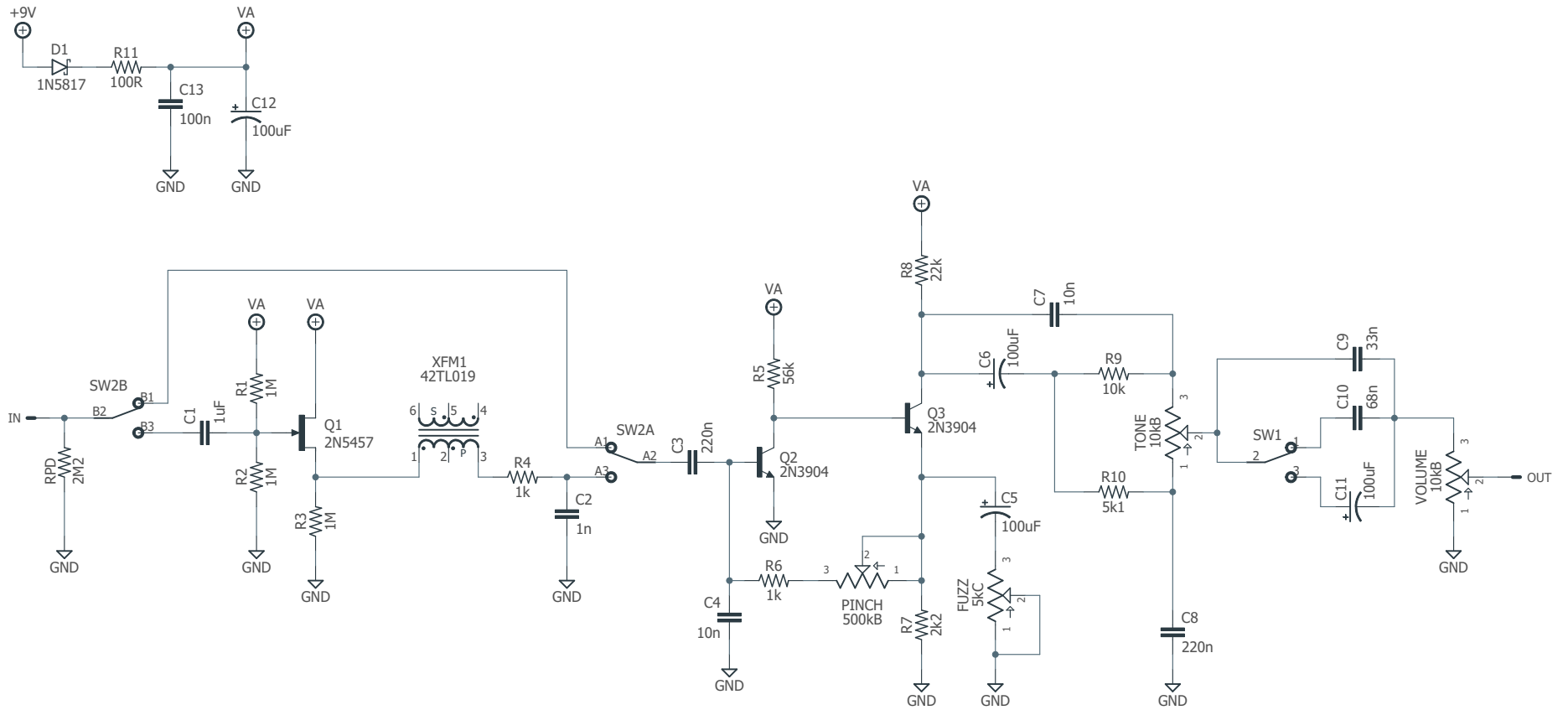

DRILL TEMPLATE

Cut out this drill template, fold the edges and tape it to the enclosure. Before drilling, it's recommended to first use a center punch for each of the holes to help guide the drill bit.

Ensure that this template is printed at 100% or "Actual Size". You can double-check this by measuring the scale on the printed page.

Top jack layout assumes the use of closed-frame jacks like the [Switchcraft 111X](#). If you'd rather use open-frame jacks, please refer to the Open-Frame Jack Drill Template for the top side.

LED hole drill size assumes the use of a [5mm LED bezel](#), available from several parts suppliers. Adjust size accordingly if using something different, such as a 3mm bezel, a plastic bezel, or just a plain LED.

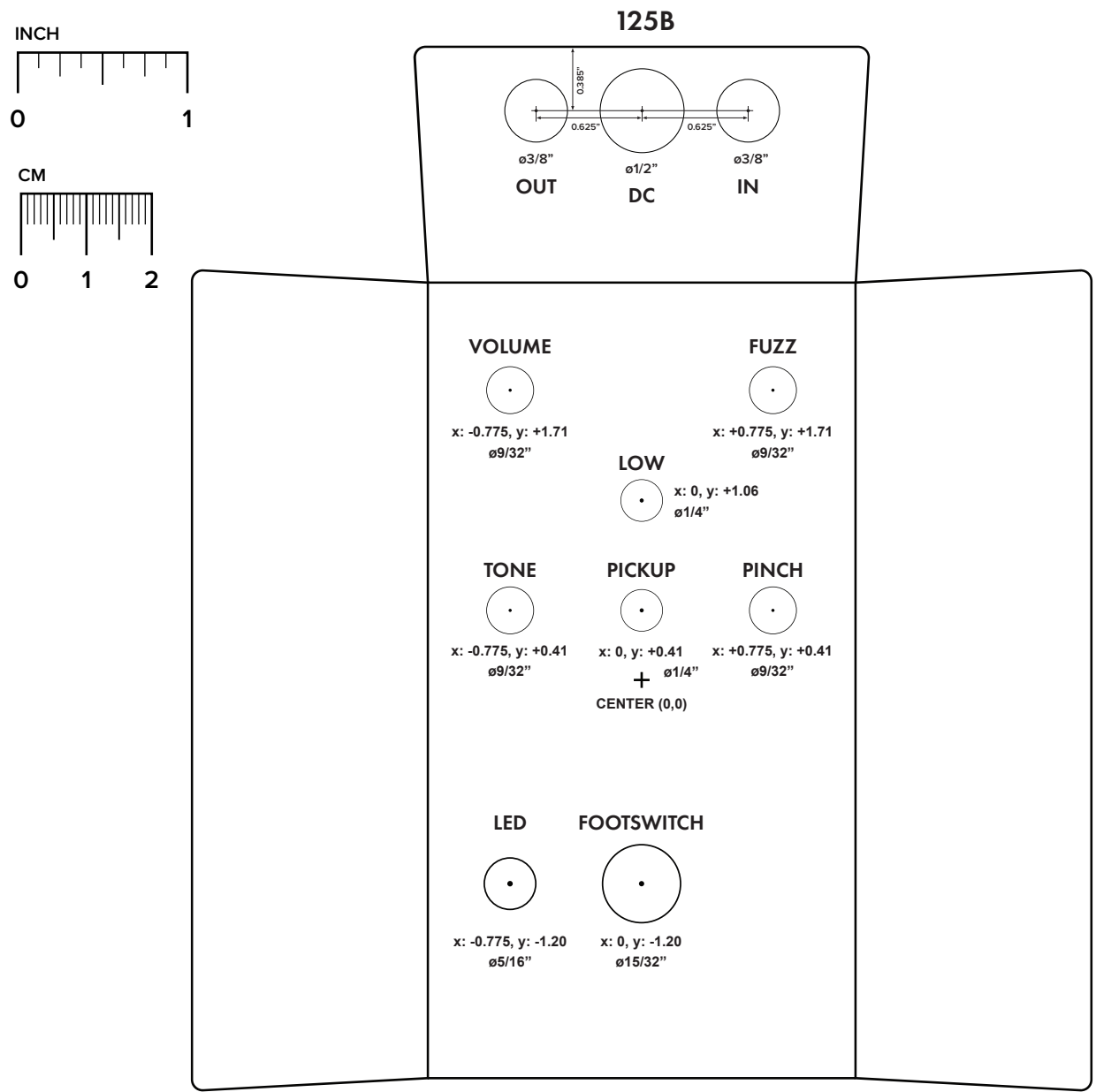

ENCLOSURE LAYOUT

Enclosure is shown without jacks. See next page for jack layout and wiring.

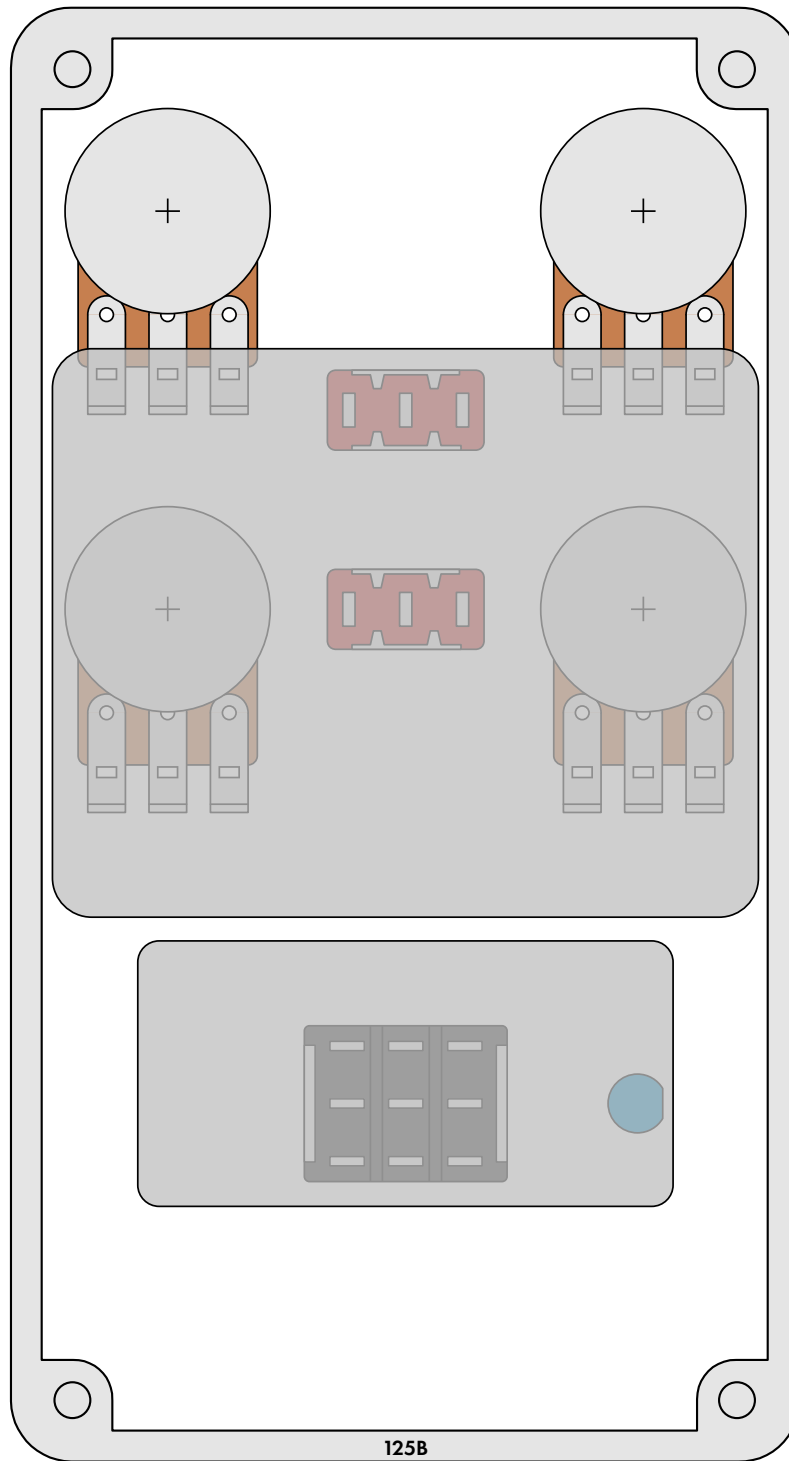

WIRING DIAGRAM

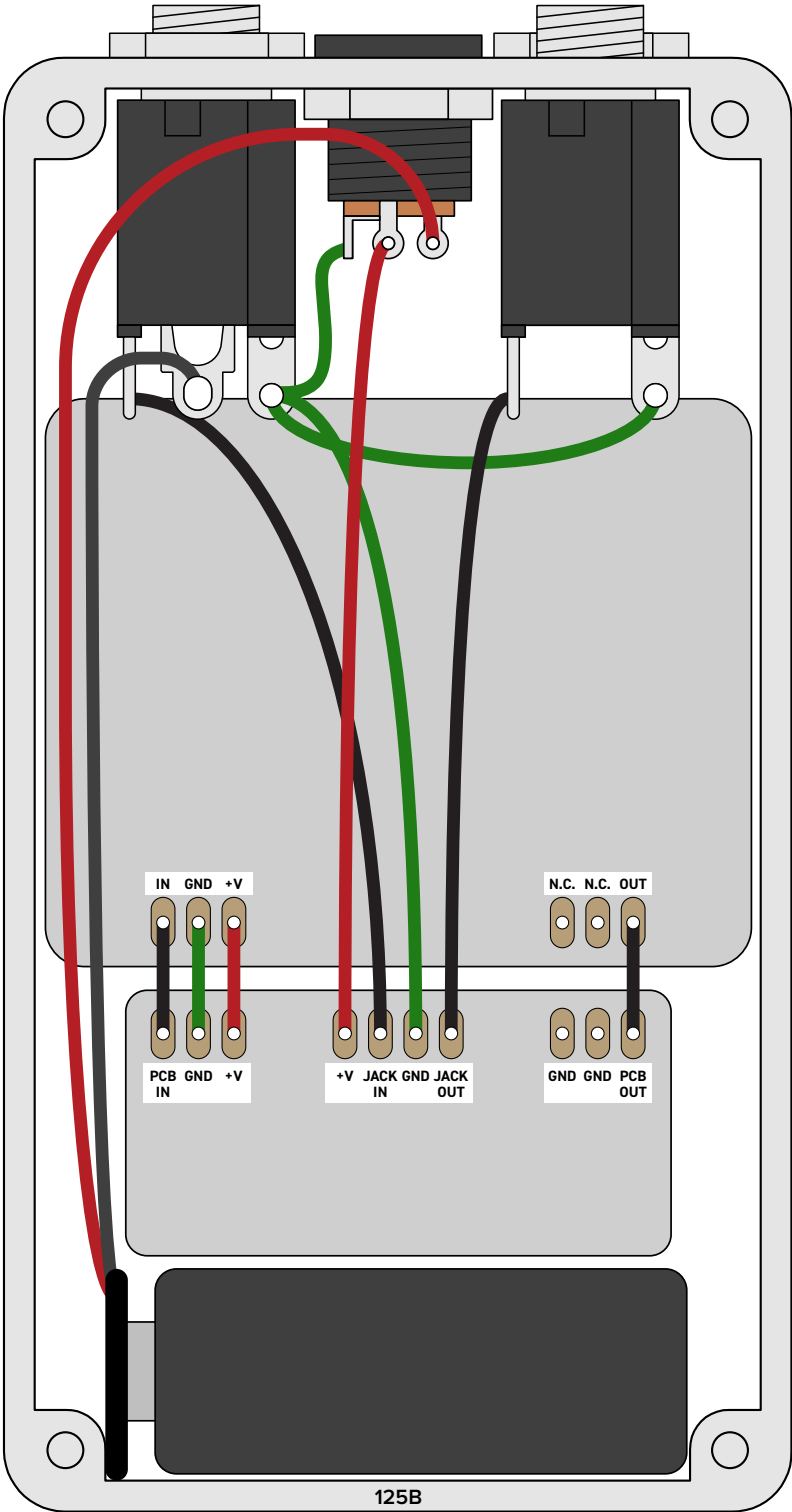

LICENSE & USAGE

No direct support is offered for these projects beyond the provided documentation. It's assumed that you have at least some experience building pedals before starting one of these. Replacements and refunds cannot be offered unless it can be shown that the circuit or documentation are in error.

All of these circuits have been tested in good faith in their base configurations. However, not all the modifications or variations have necessarily been tested. These are offered only as suggestions based on the experience and opinions of others.

Projects may be used for commercial endeavors in any quantity unless specifically noted. No attribution is necessary, though a link back is always greatly appreciated. The only usage restrictions are that **(1) you cannot resell the PCB as part of a kit without prior arrangement, and (2) you cannot "goop" the circuit, scratch off the screenprint, or otherwise obfuscate the circuit to disguise its source.** (In other words: you don't have to go out of your way to advertise the fact that you use these PCBs, but please don't go out of your way to hide it. The guitar effects industry needs more transparency, not less!)

DOCUMENT REVISIONS

1.0.0 (2019-08-31)

Initial release.