

PROJECT NAME

PEPPERMILL

BASED ON

Runoffgroove Peppermill

BUILD DIFFICULTY

■■■■■ Easy

EFFECT TYPE

JFET overdrive

DOCUMENT VERSION

1.0.0 (2020-06-05)

PROJECT SUMMARY

A super-simple drive created by boosting the signal into a J201 JFET until it clips in a tube-like manner.

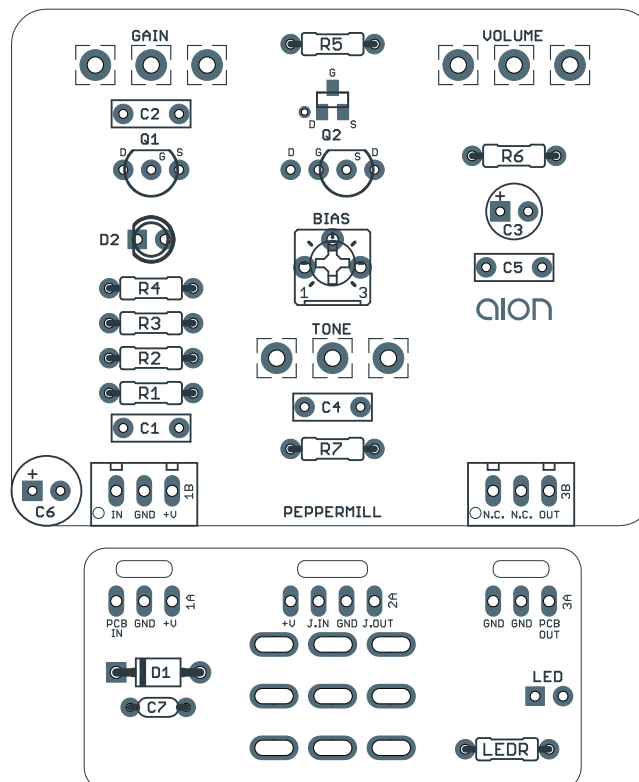

Actual size is 2.3" x 1.86" (main board) and 1.78" x 0.86" (bypass board).

TABLE OF CONTENTS

1	Project Overview	6	Drill Template
2	Introduction & Usage	7	Enclosure Layout
3	Parts List	8	Wiring Diagram
4	Build Notes	9	Licensing
5	Schematic	9	Document Revisions

INTRODUCTION

The Runoffgroove Peppermill is a simple circuit designed to showcase the tube-like clipping characteristics of the J201. It's a very minimalist design which is composed of nothing more than a MOSFET gain-boost stage into a JFET. The gain can be adjusted between the two stages to control the amount of clipping, and an output volume is present at the end, and that's it.

The Aion FX version of the Peppermill is a direct adaptation of the original circuit, with one modification: the addition of a tone control. The original circuit has a R-C lowpass filter right before the volume, and by making the resistor value adjustable, you end up with a useful tone control without otherwise affecting the original circuit.

Since the J201 is very difficult to find in TO-92 through-hole format, and many DIY hobbyists are intimidated by SMD parts, Aion FX offers [J201s in SMD format](#) that have been pre-soldered to adapters so they can be used as through-hole parts.

USAGE

The Peppermill has the following controls:

- **Drive** controls the volume going into the JFET clipping stage. At higher drive levels, the JFET will overload and clip the signal.
- **Tone** is a simple passive high-pass filter that can be adjusted for more or less treble.
- **Volume** controls the overall output of the effect.

PARTS LIST

This parts list is also available in a spreadsheet format which can be imported directly into Mouser for easy parts ordering. Mouser doesn't carry all the parts (most notably potentiometers) so the second tab lists all the non-Mouser parts as well as sources for each.

[View parts list spreadsheet](#) →

PART	VALUE	TYPE	NOTES
R1	1M	Metal film resistor, 1/4W	
R2	1M	Metal film resistor, 1/4W	
R3	4k7	Metal film resistor, 1/4W	
R4	1k	Metal film resistor, 1/4W	
R5	100k	Metal film resistor, 1/4W	
R6	1k	Metal film resistor, 1/4W	
R7	5k1	Metal film resistor, 1/4W	
RPD	2M2	Metal film resistor, 1/4W	Input pulldown resistor.
LEDR	4k7	Metal film resistor, 1/4W	LED current-limiting resistor. Adjust value to change LED brightness.
C1	22n	Film capacitor, 7.2 x 2.5mm	
C2	68n	Film capacitor, 7.2 x 2.5mm	
C3	1uF	Electrolytic capacitor, 4mm	
C4	47n	Film capacitor, 7.2 x 2.5mm	
C5	2n2	Film capacitor, 7.2 x 2.5mm	
C6	100uF	Electrolytic capacitor, 6.3mm	Power supply filter capacitor.
C7	100n	MLCC capacitor, X7R	Power supply filter capacitor.
D1	1N5817	Schottky diode, DO-41	
D2	3mm LED	LED, 3mm, red diffused	
Q1	2N7000	MOSFET, N-channel, TO-92	
Q2	J201	JFET, N-channel, TO-92 or SOT-23	Can use either J201 (through-hole) or MMBFJ201 (SMD).
BIAS	50k trimmer	Trimmer, 10%, 1/4"	
TONE	100kC	16mm right-angle PCB mount pot	
GAIN	250kB	16mm right-angle PCB mount pot	
VOL.	100kA	16mm right-angle PCB mount pot	
LED	5mm	LED, 5mm, red diffused	
IN	1/4" stereo	1/4" phone jack, closed frame	Switchcraft 112BX or equivalent.
OUT	1/4" mono	1/4" phone jack, closed frame	Switchcraft 111X or equivalent.
DC	2.1mm	DC jack, 2.1mm panel mount	Mouser 163-4302-E or equivalent.
BATT	Battery snap	9V battery snap	Optional. Use the soft plastic type—the hard-shell type will not fit.
FSW	3PDT	Stomp switch, 3PDT	
ENC	125B	Enclosure, die-cast aluminum	Can also use a Hammond 1590N1.

BUILD NOTES

Setting bias trimmers

Turn the trimmers so that the drain (“D” pad) of the JFETs measure 4.5V with a multimeter (red probe to “D” pad and black probe to ground). This is just a guideline, though—you can tweak the trimmers a bit to fine-tune the circuit to your liking. The bias affects the total gain of the circuit, so you can make it a little cleaner or a little dirtier than stock.

J201 usage

The J201 transistor is very popular in DIY pedal designs, but was discontinued in TO-92 through-hole format several years ago and is becoming very scarce. Genuine parts are getting expensive and many counterfeits have entered the market.

The MMBFJ201 is a SMD version that is still in production. On the PCB, two outlines have been included for each individual JFET, one for TO-92 and one for SMD (called SOT-23) right next to it. Make sure you only use one or the other—don’t put both a through-hole and surface mount part in the two Q1 spots.

J201 adapters

Many DIY builders are intimidated by the small size of surface-mount parts. Aion FX offers [pre-soldered J201s on adapters](#) so they can easily be used as through-hole parts.

SCHEMATIC

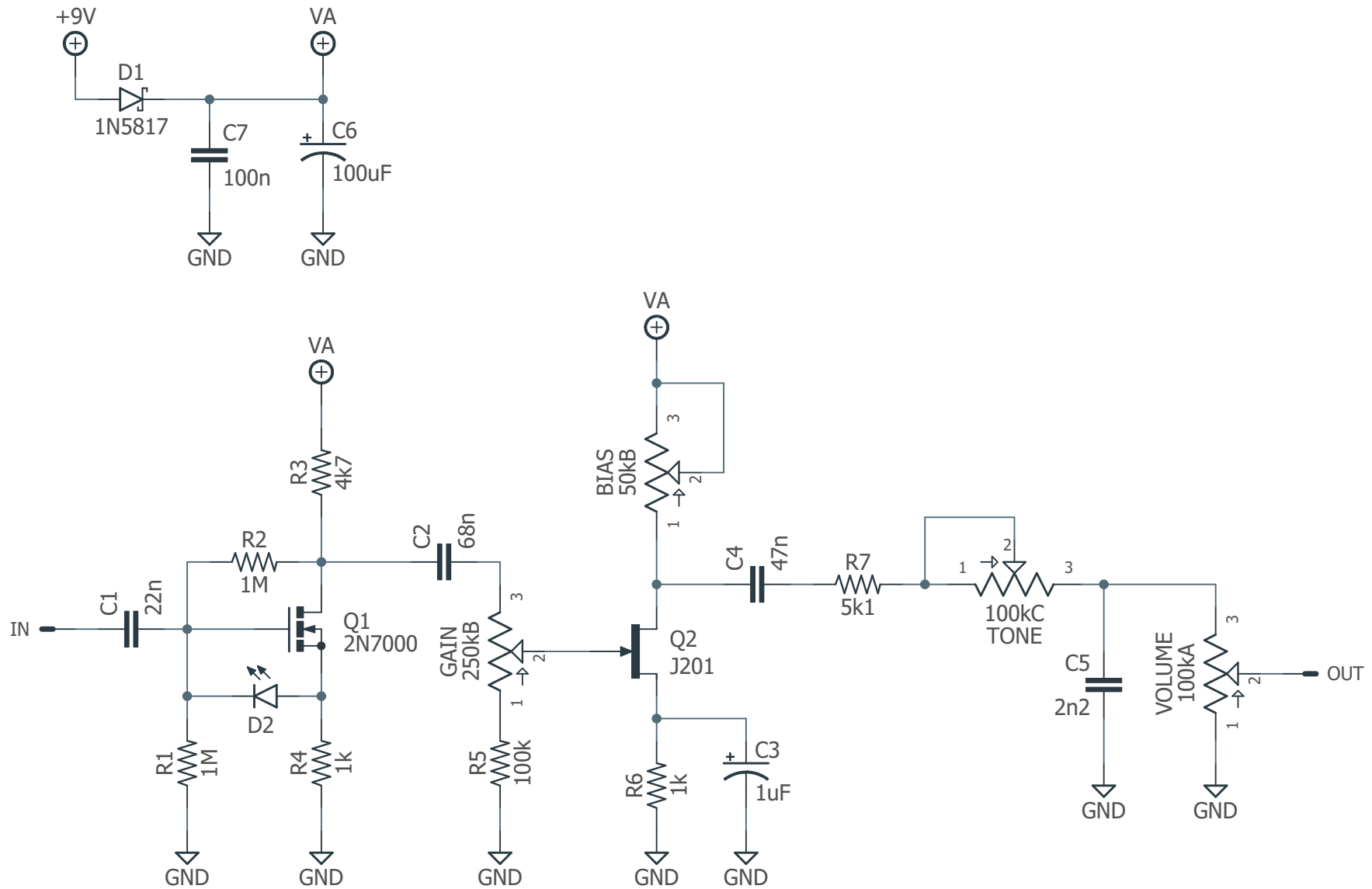

DRILL TEMPLATE

Cut out this drill template, fold the edges and tape it to the enclosure. Before drilling, it's recommended to first use a center punch for each of the holes to help guide the drill bit.

Ensure that this template is printed at 100% or "Actual Size". You can double-check this by measuring the scale on the printed page.

Top jack layout assumes the use of closed-frame jacks like the [Switchcraft 111X](#). If you'd rather use open-frame jacks, please refer to the Open-Frame Jack Drill Template for the top side.

LED hole drill size assumes the use of a [5mm LED bezel](#), available from several parts suppliers. Adjust size accordingly if using something different, such as a 3mm bezel, a plastic bezel, or just a plain LED.

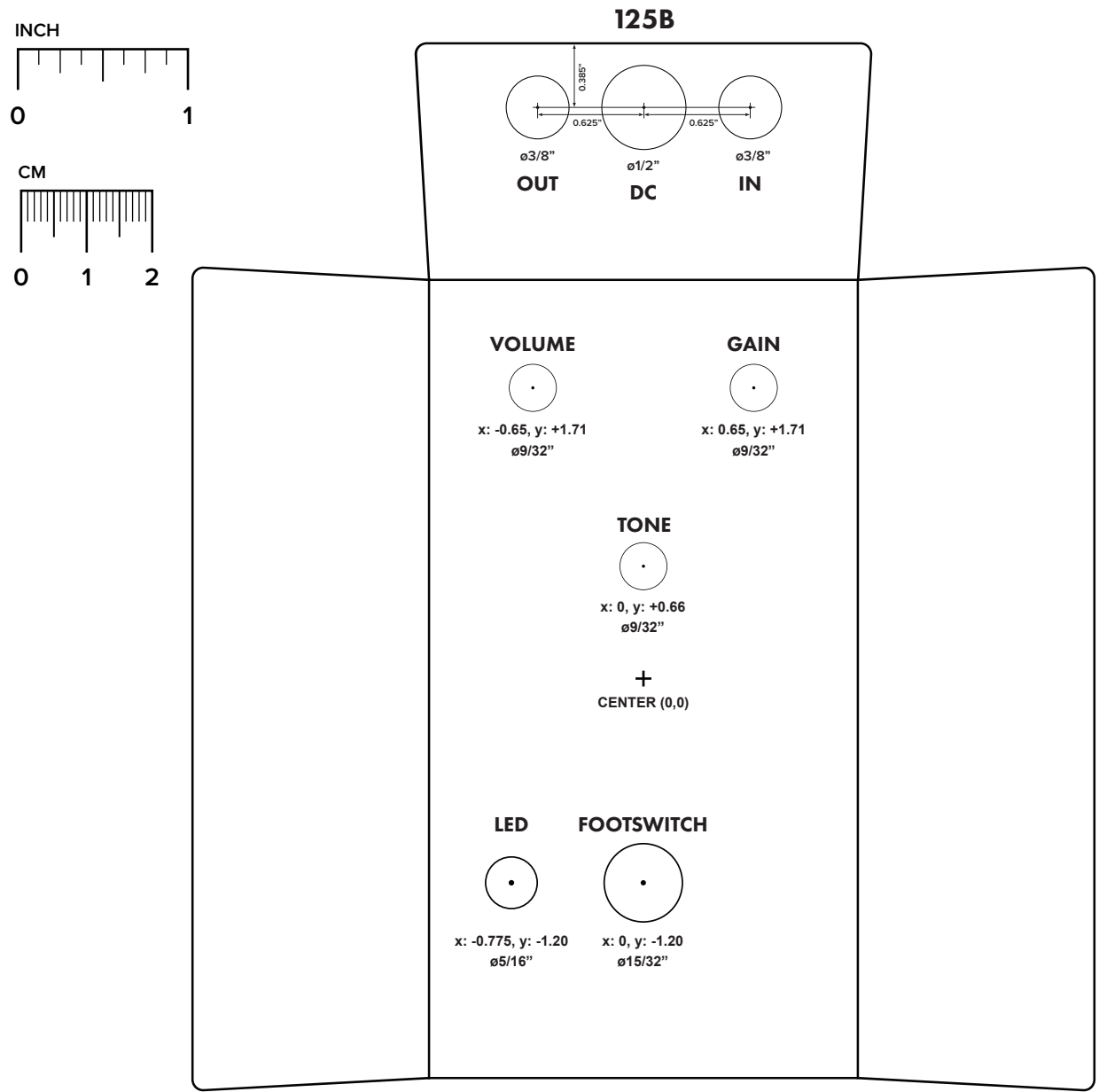

ENCLOSURE LAYOUT

Enclosure is shown without jacks. See next page for jack layout and wiring.

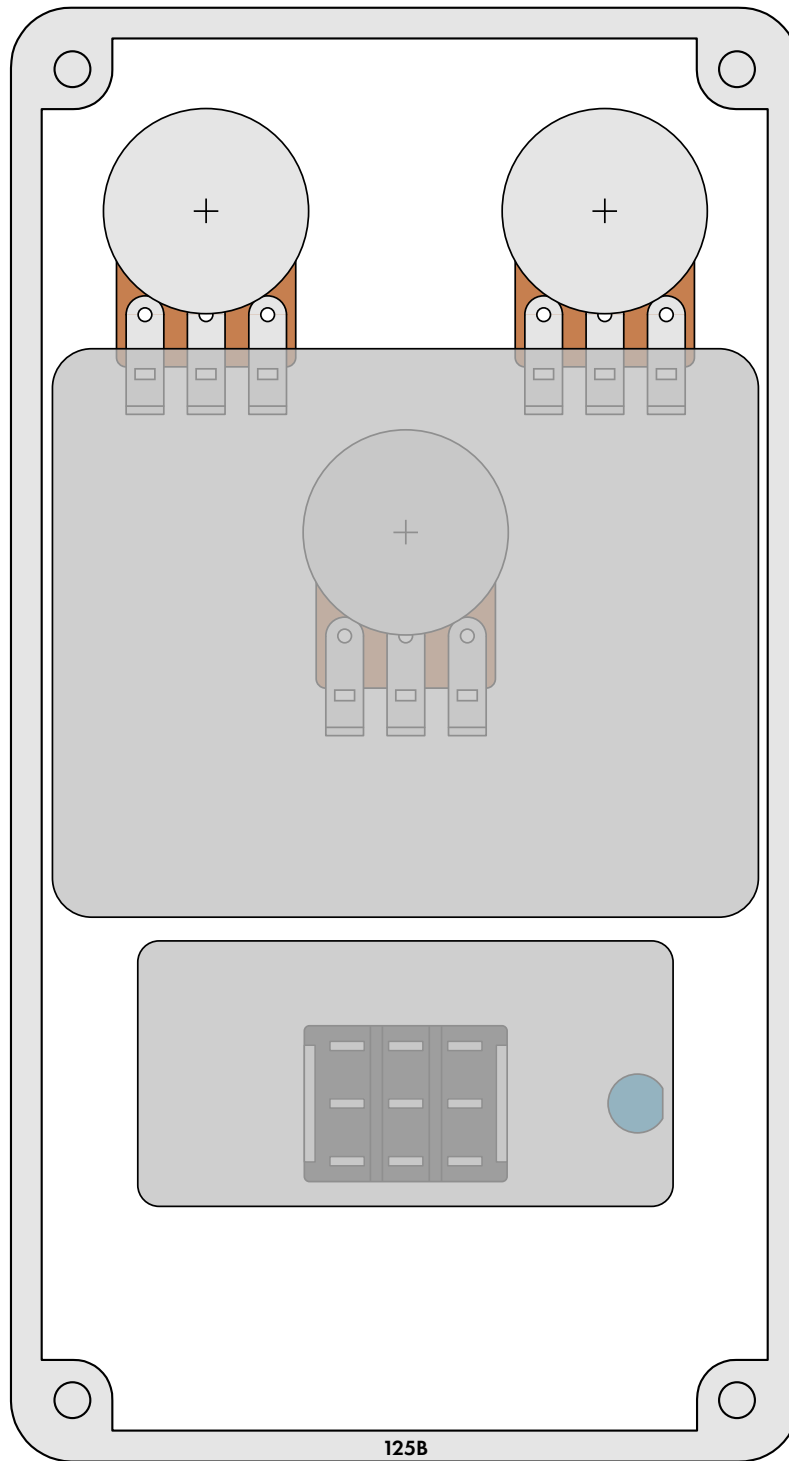

WIRING DIAGRAM

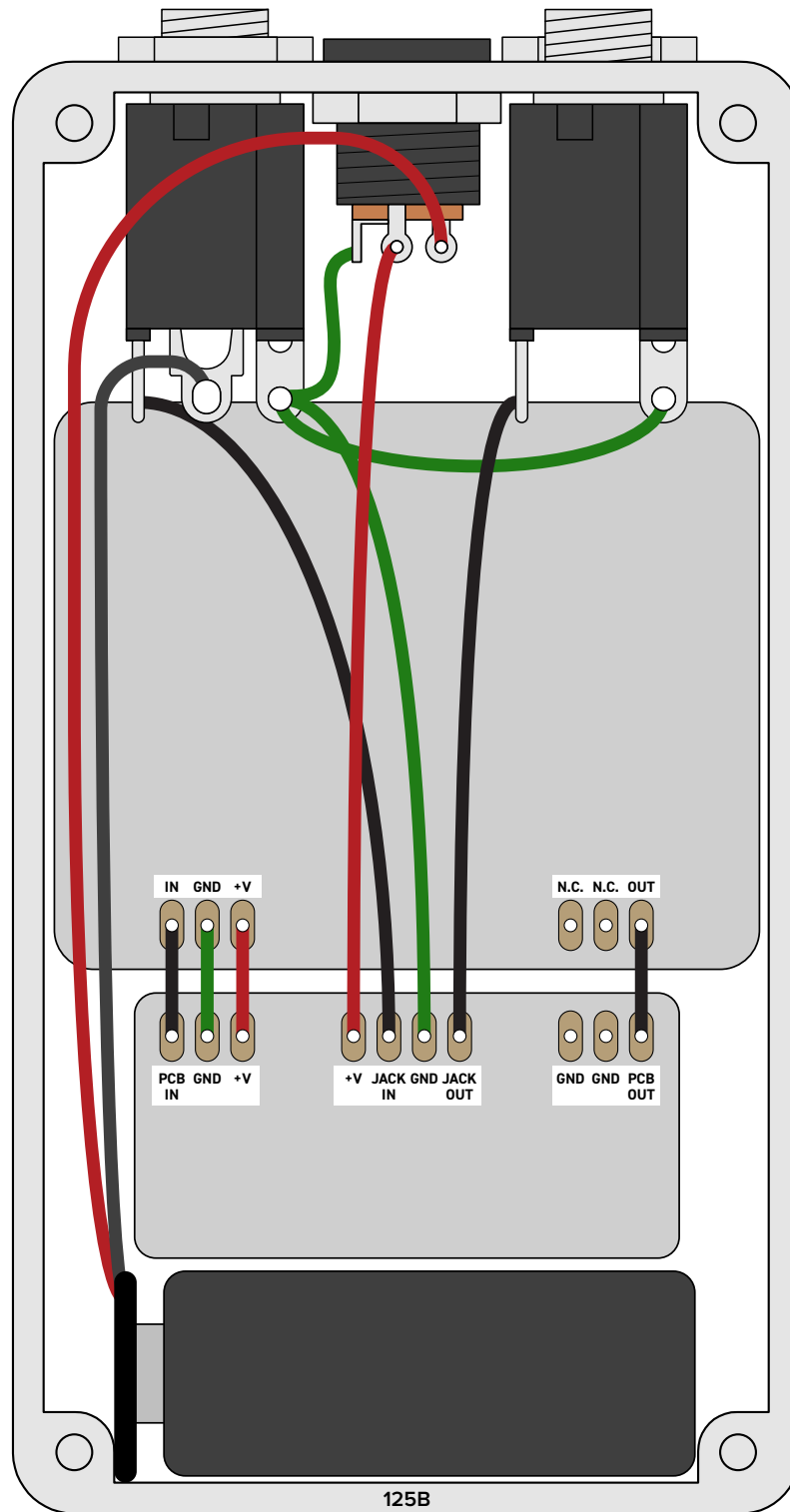

*Shown with optional 9V battery. If battery is omitted, both jacks can be mono rather than one being stereo.
Leave the far-right lug of the DC jack unconnected.*

LICENSE & USAGE

No direct support is offered for these projects beyond the provided documentation. It's assumed that you have at least some experience building pedals before starting one of these. Replacements and refunds cannot be offered unless it can be shown that the circuit or documentation are in error.

All of these circuits have been tested in good faith in their base configurations. However, not all the modifications or variations have necessarily been tested. These are offered only as suggestions based on the experience and opinions of others.

Runoffgroove circuit licensing

Runoffgroove circuits have special licensing that is different from standard Aion FX projects. **These projects are for personal use only and may not be used for commercial endeavors** without approval from Runoffgroove. Here are the terms of use from their site:

runoffgroove.com projects are provided free-of-charge to builders for personal, non-commercial use. We do offer licensing for builders who wish to sell pedals based on, in whole or in part, our projects. As part of the licensing agreement, the builder must clearly state that the circuit was developed by runoffgroove.com, both in promotional literature and on the circuit board. If you see a pedal for sale that seems to be based on a runoffgroove.com project and does not credit us, the builder may not be officially licensed by us and therefore, not compensating us as the developer. Please contact us with the information and we will investigate the situation. Thank you.

DOCUMENT REVISIONS

1.0.0 (2020-06-05)

Initial release.